

PHOTOVOLTAICS

Direct Conversion of Sunlight to Electricity

David T Britton,
NanoSciences Innovation Centre
University of Cape Town

Photovoltaic effect

Early (simple) solar cells: 1839 –

Heterojunction solar cells: 1946 –

- principle of operation
- commercial solar cells and modules

Distributed junction solar cells

State of the Art?

PHOTOVOLTAIC EFFECT

Light generates free charges

Photochemical

Edmond Becquerel,
Comptes Rendus **9**, 561 – 567 (1839)

electrons and ions

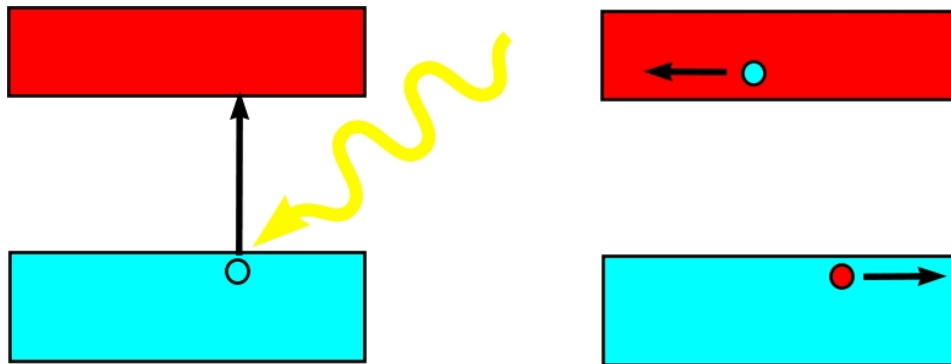
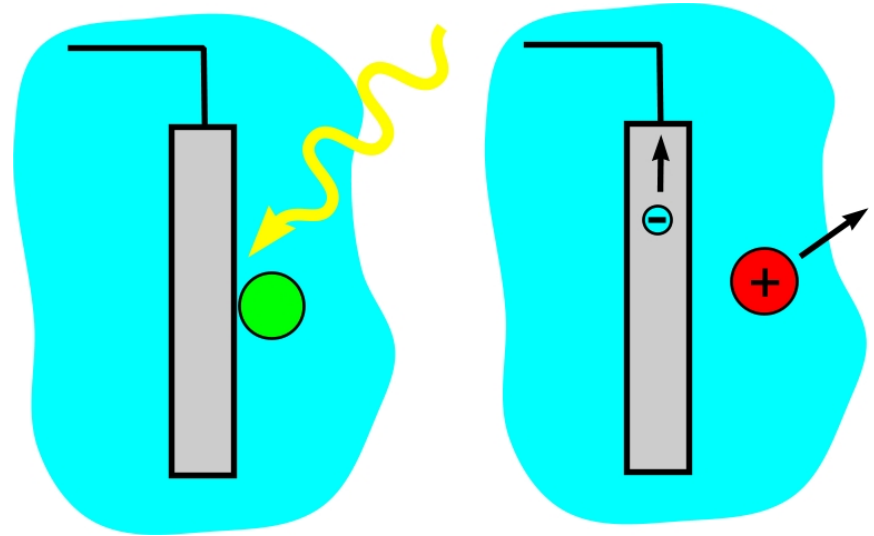

Solid State

W.G. Adams & R.E. Day,
Proc Roy Soc Lond **25**, 113 -117 (1876)

electrons and holes

SIMPLE SOLAR CELLS

(photoresistors)

Single homogeneous material between two contacts
Diffusion/drift of charge to one electrode gives current
Voltage is low

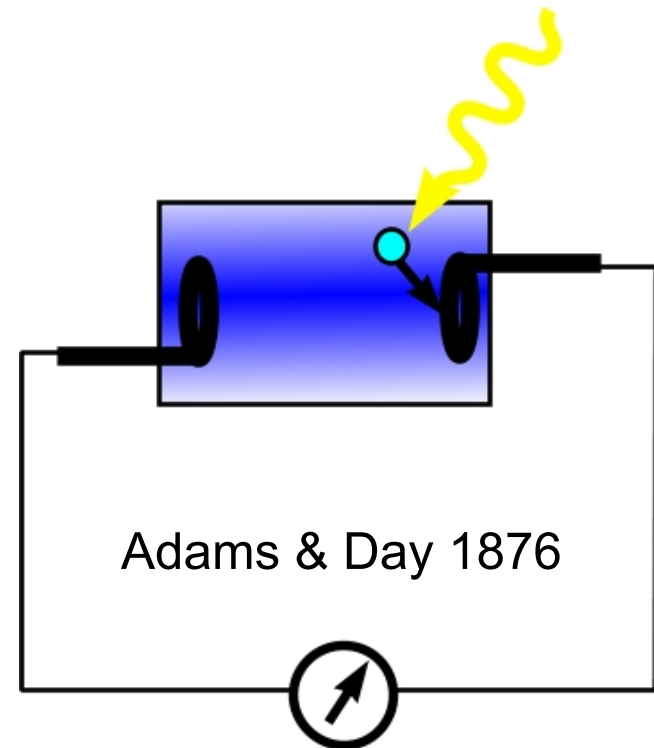
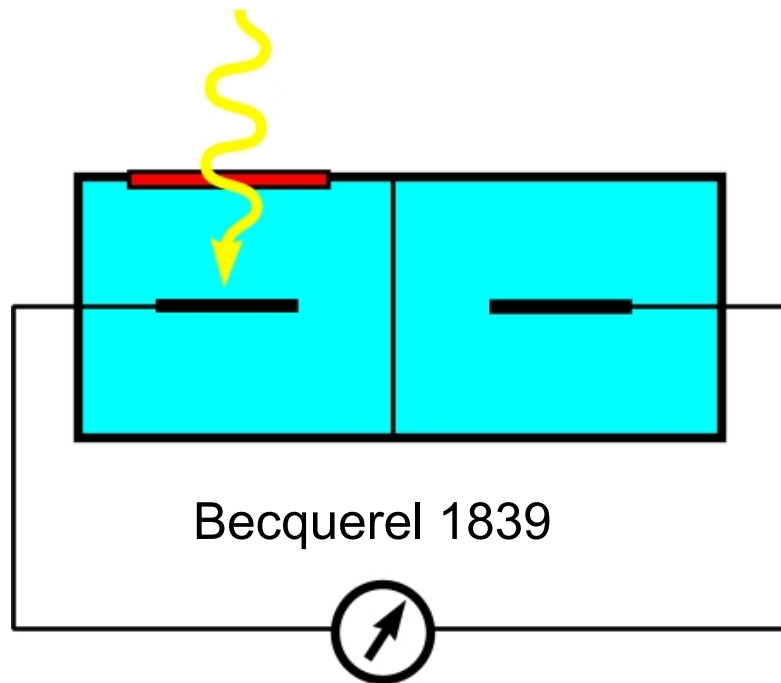

illuminated electrode is cathode

SIMPLE SOLAR CELLS

(photoconductors)

First thin film solar cell Charles Fritts 1882
Selenium with thin gold leaf front electrode,
(transparent to green light)
tin plated back electrode
Am J. Sci **26**, 465 – 482 (1883)

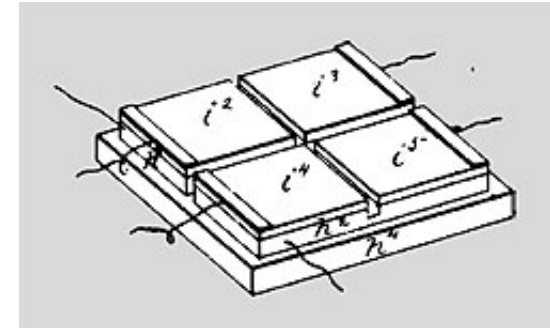

PV discovered in Fritts cell by W. Siemens
Sitzungsber. Preuss. Akad. Wiss zu Berlin
1885 (I), 147-148

Screen printed CdS, CdSe Y. T Sivhonen &
S.G. Parker 1963, (Texas Instruments)
US 3208022 (1965)

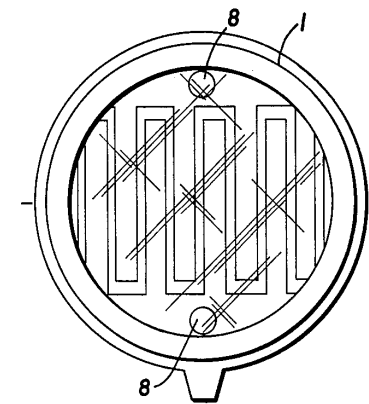

First fully printed silicon cell 2008

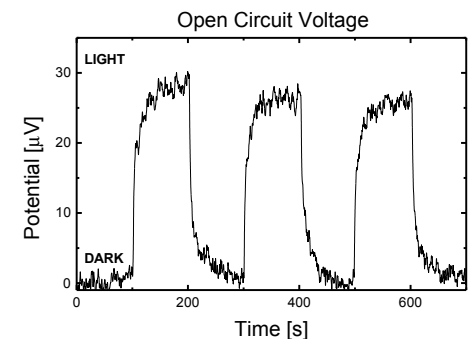
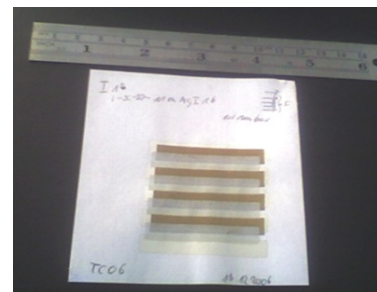

HETEROJUNCTION SOLAR CELLS

(photodiodes)

Inbuilt electric field
Anode and Cathode given by diode direction

dark

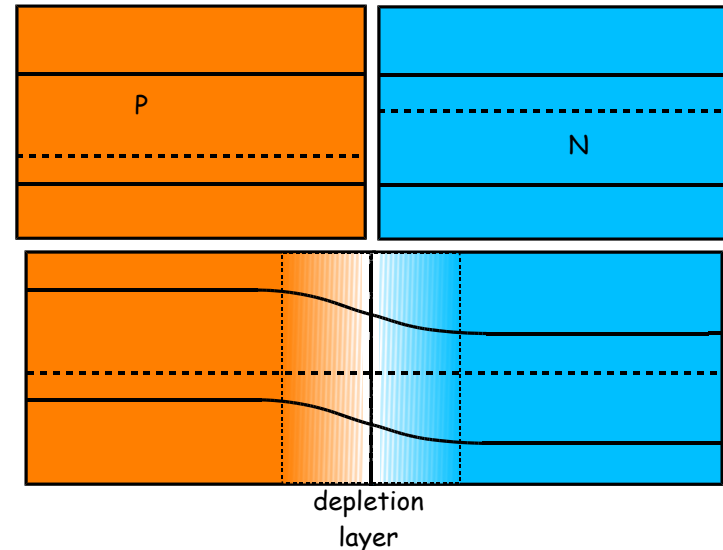

light

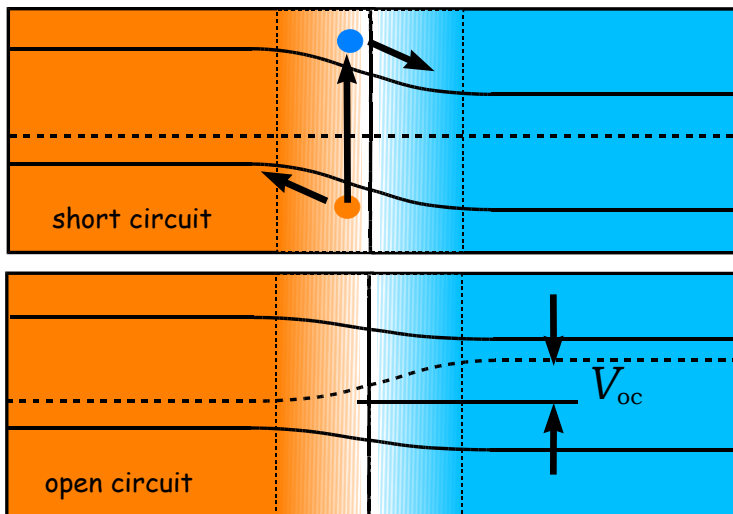

electrons & holes produced in the junction
electrons pulled to n-type layer
holes pulled to p-type layer

Short circuit current j_{sc} is from n to p
Open circuit : charge collection gives V_{oc}

$$j = j_0 \left(e^{eV/kT} - 1 \right) - j_{sc} \quad V_{oc} = \frac{kT}{e} \ln \left(1 + \frac{j_{sc}}{j_0} \right)$$

HETEROJUNCTION SOLAR CELLS

Equivalent circuit

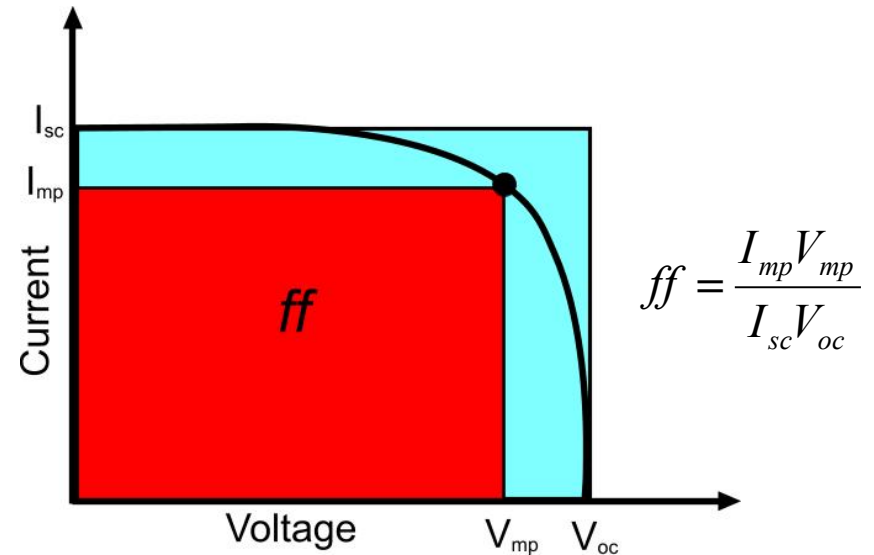
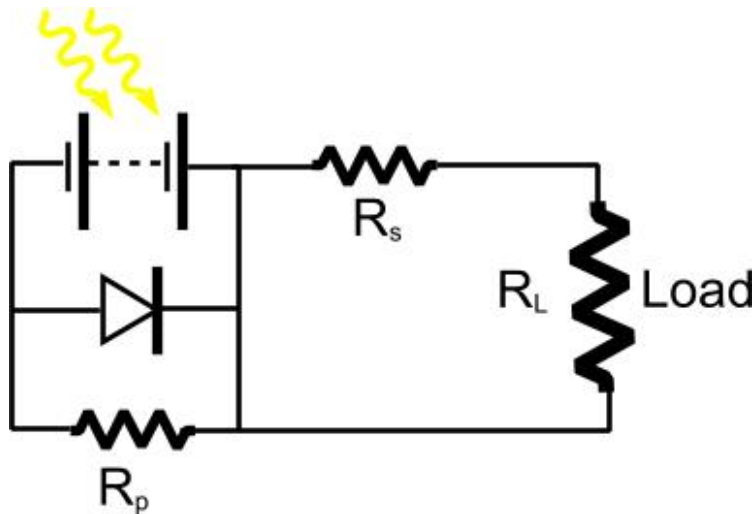

Quantum Efficiency (QE) = number charge carriers/number of photons

Internal quantum efficiency (IQE): only absorbed photons

External quantum efficiency (EQE): all photons hitting the cell

Cell efficiency η : maximum electrical power out/ radiant energy in

Module efficiency: useful power out/radiant energy in

$$\eta = \frac{I_{mp} V_{mp}}{EA} = ff \frac{I_{sc} V_{oc}}{EA}$$

Standard test conditions (IEC 6125)

1kW/m² 25 °C AM1.5 sunlight spectrum

1 cm² cell

HETEROJUNCTION SOLAR CELLS

Silicon pn junction cell (Bell Labs) 1941
 R.S. Ohls, US Patent 2402662 (1946)

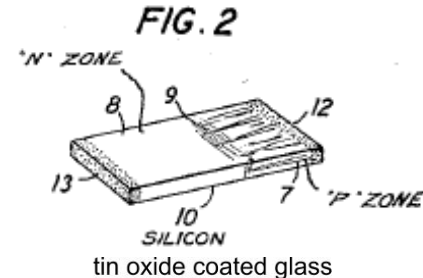

First organic PV (OPV) cell
 D. Kearns & M. Calvin,
 J Chem. Phys 29, 950-951 (1958)

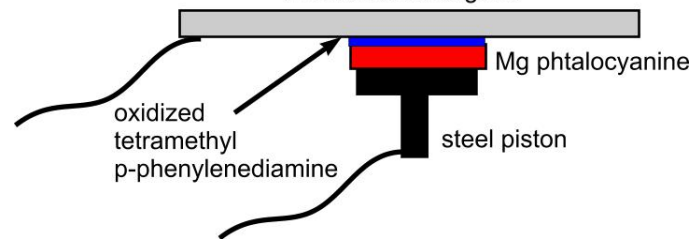

GaAs solar cells 1970
 Thin film a-Si:H (RCA 1976)

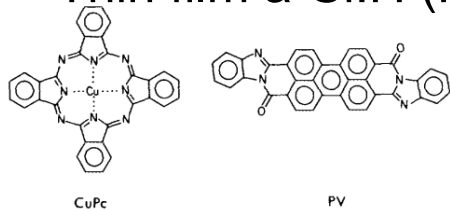

Thin film OPV, C.W. Tang, Appl Phys Lett 42, 183 – 185 (1985)

Modern commercial solar cells

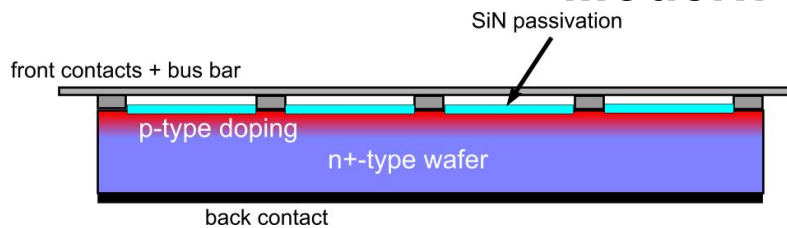

Crystalline

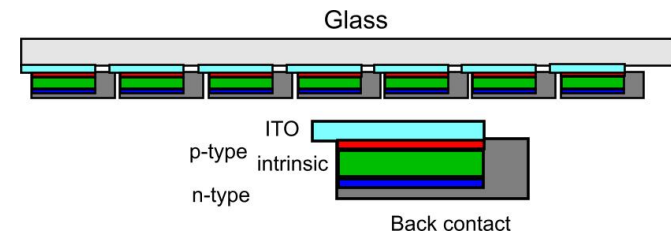

Thin film

Other geometries include tandem cells and graded junctions

DISTRIBUTED JUNCTION SOLAR CELLS

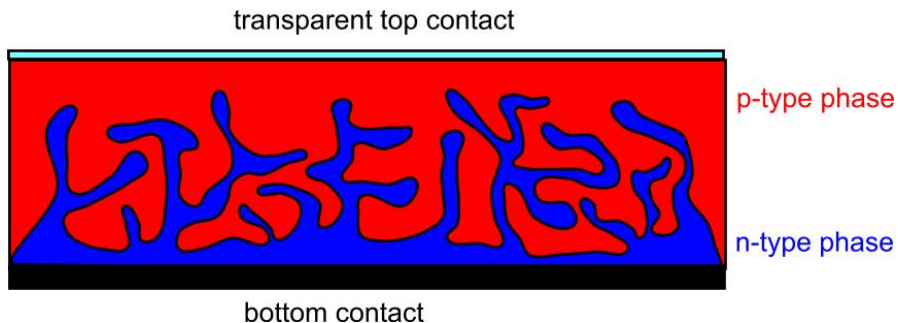

Only one layer of mixed material
 More light reaches the junction
 Larger junction
 shorter distance for charge to travel

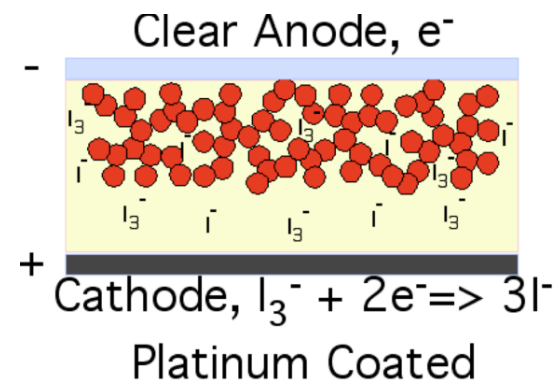

Dye Sensitised Solar Cell (Photochemical)
 B. O'Regan & **M. Grätzel**, Nature **353**, 737-740 (1991)

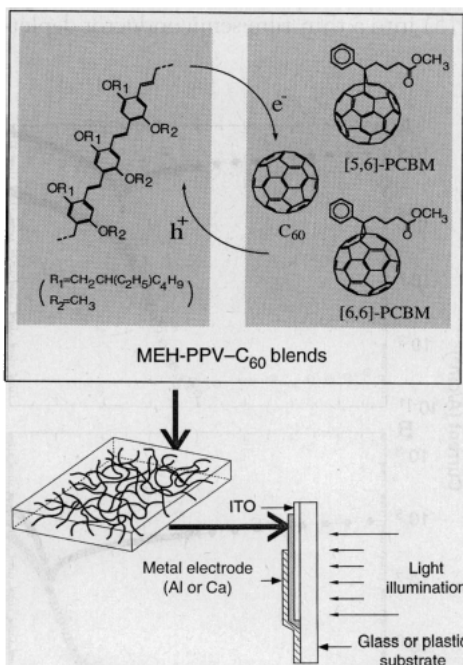

Polymer – fullerene blends (OPV)
 G. Yu, J. Gao, J.C. Humelen, F. Wudl, and **A.J. Heeger**

Alan Heeger & Michael Grätzel are founders of **Konarka**



STATE OF THE ART?

Best Research-Cell Efficiencies

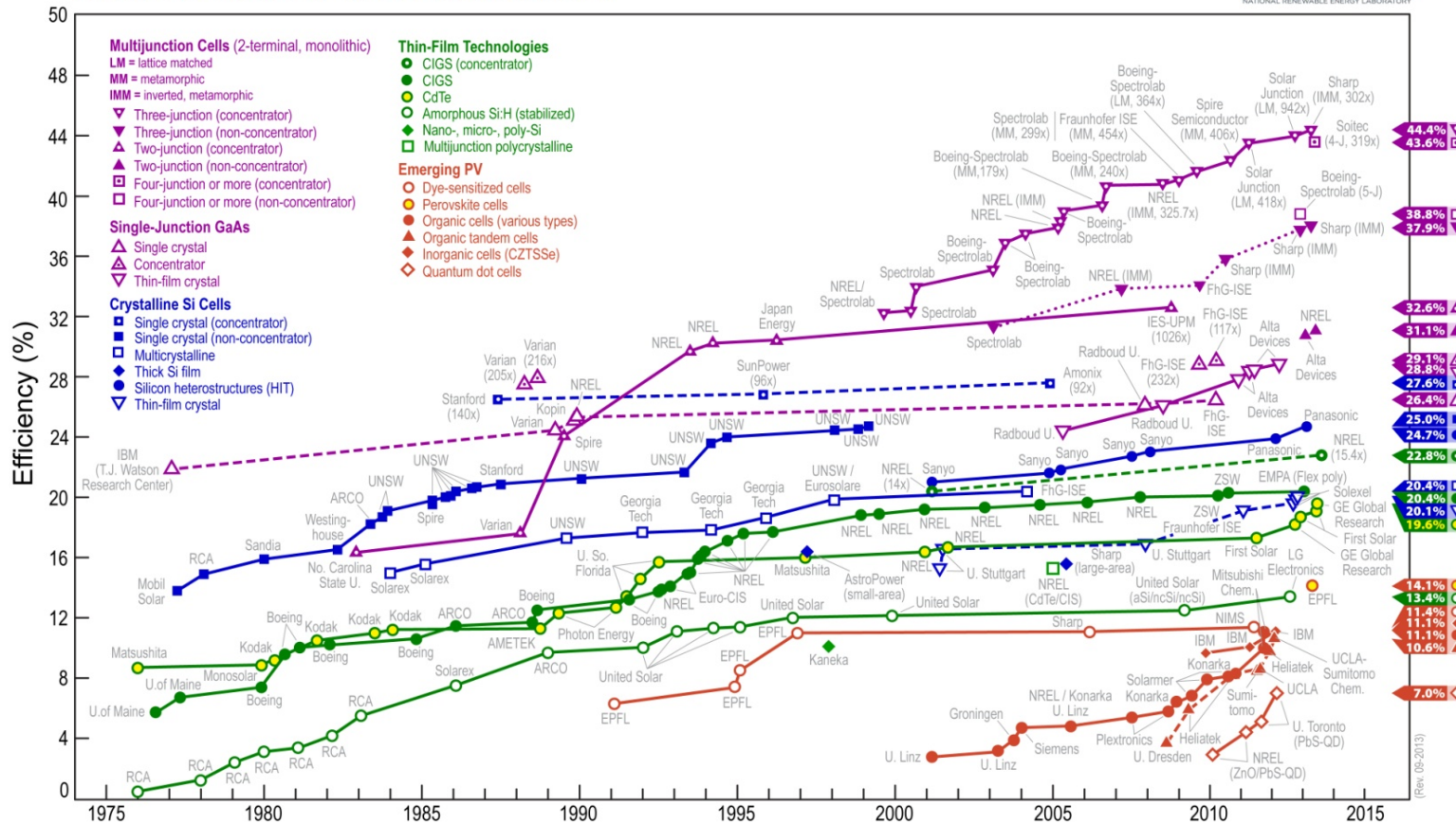

2010/06/14

Sharp

44.4%

Other factors to discuss:

Industrial scalability

price per Wp

cost per kWh

Are they green?

Sharp Develops Concentrator Solar Cell with World's Highest Conversion Efficiency of 44.4%

Sets New Record with Concentrator Triple-Junction Compound Solar Cell

■ Concentrator solar cell system

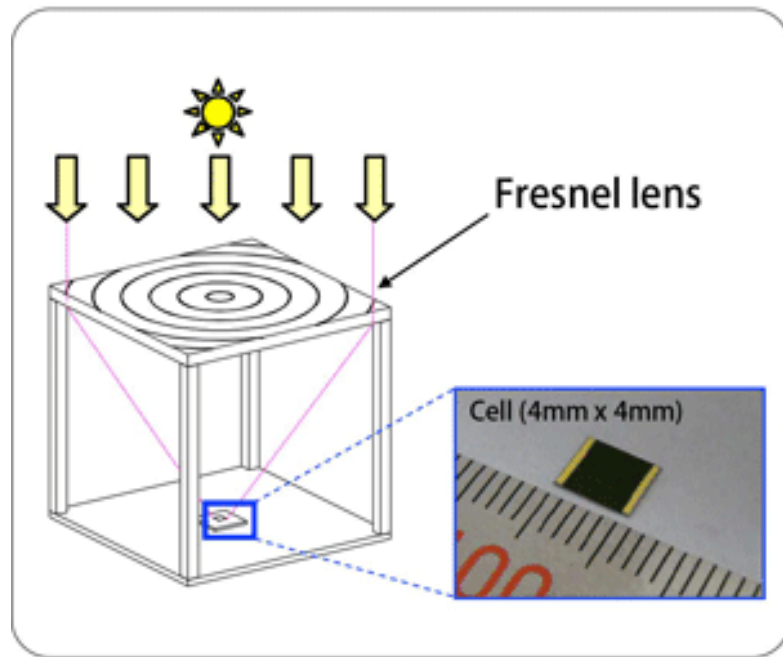

■ Structure of a triple-junction compound solar cell

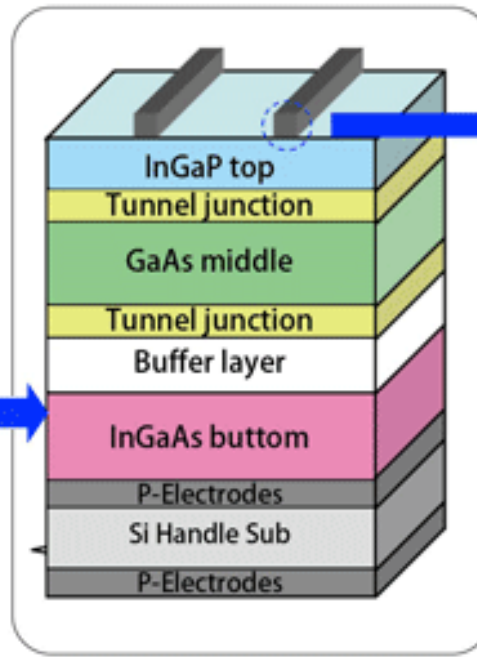

■ Comparison with a conventional structure

