

global community design partnering for health in rural Tanzania



Village Life Outreach Project [VLOP] & the Shirati Health, Education and Development Foundation [SHED].

Michael Zaretsky, Assistant Professor in the School of Architecture and Interior Design [SAID] at the University of Cincinnati, in collaboration with University of Cincinnati faculty and students

 **VILLAGE LIFE**
Outreach Project

 **SHED**
Foundation

UNIVERSITY OF
Cincinnati

location

rural NW Tanzania

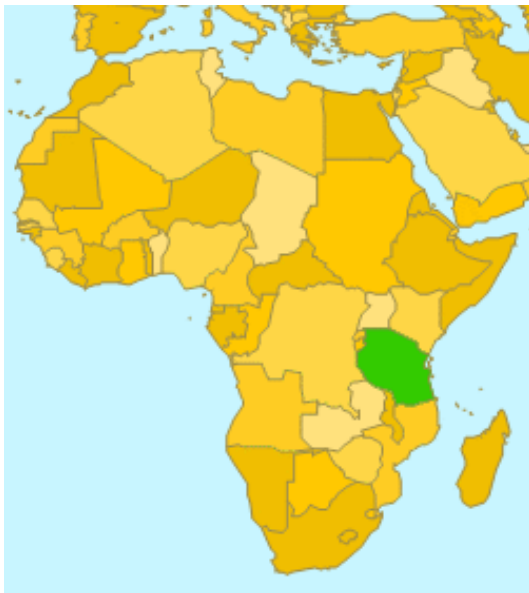

Regions of Zanzibar^a

- 1 Pemba North
- 2 Pemba South
- 3 Zanzibar North
- 4 Zanzibar Urban/West
- 5 Zanzibar Central/South

^a Zanzibar comprises the islands of Zanzibar and Pemba.

Tanzania

- International boundary
- - - Region boundary
- ★ National capital
- ⊙ Region capital
- +— Railroad
- Road

0 150 Kilometers
0 150 Miles

Boundary representation is not necessarily authoritative.

location

local site data

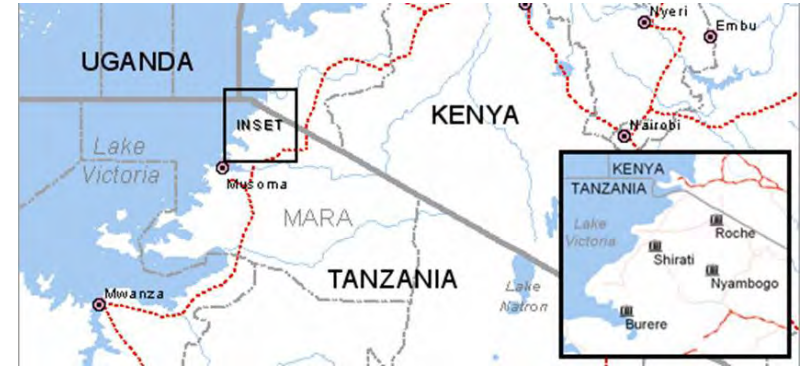

The site for the health center is in **Roche Village**, Tanzania.

Roche Village:

- Altitude of 1,132 m (3,717 ft)
- Latitude: 1° 12' S
- Longitude: 34° 02' E

The base of operations when VLOP is in Tanzania is in **Shirati**, about 20km from Roche in a similar microclimate.

Significant Topographical Features of Shirati and Roche Village include:

- Lake Victoria to the Northwest
- Mountains to the Southeast

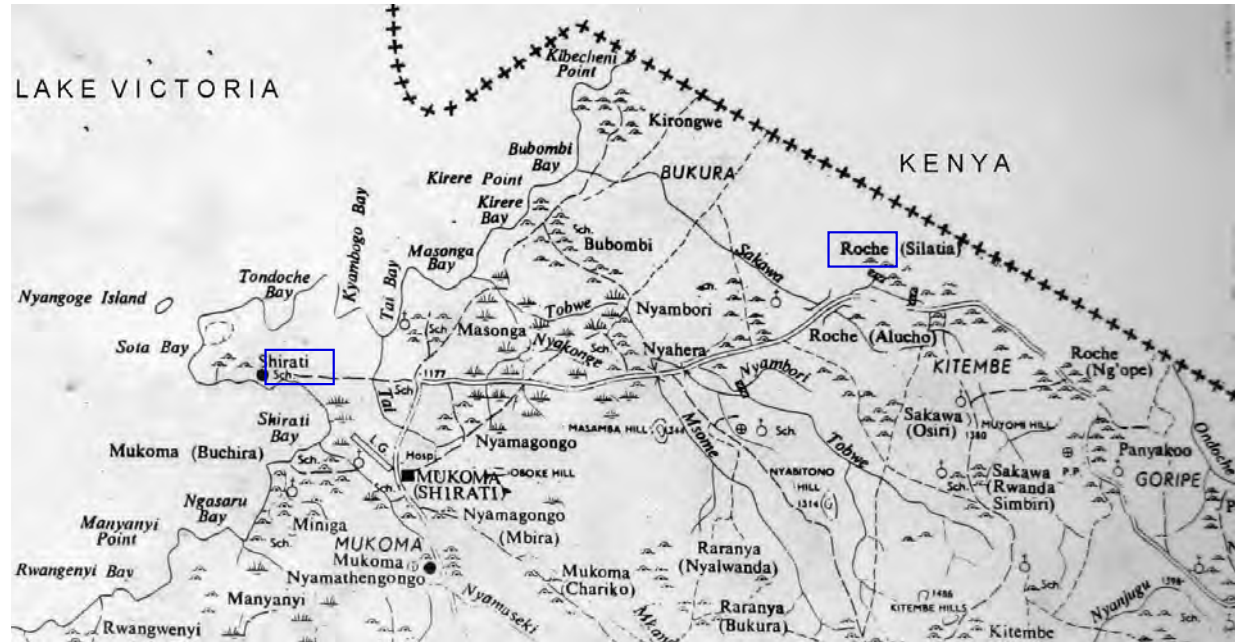

timeline

- 2002 Chris Lewis does a residency in Shirati Hospital, TZ while in UC Med School
- 2004 VLOP begins "Outreach Brigades" in the Rorya District
- 2007 VLOP begins to develop plan for health center at Roche
- 2008 spring Michael Zaretsky + UC-SAID begin research for Roche Health Center
- 2008 autumn Graduate Elective Architecture Studio
- 2008 oct MZ on October Brigade
- 2008 nov Collaboration Arup Engineers, Chicago
- 2009 winter 6 Graduate Architecture students do research on health center
- 2009 On-going research and fundraising
- 2009 autumn Graduate Elective Architecture Studio
- 2009 autumn collaboration with ARUP and Emersion Design
- 2010 mar Phase 1 RHC construction begins: Outpatient clinic (Roush on-site)
- 2010 may Borehole water is available at RHC site
- 2010 june Elliott and Zaretsky on-site, Elliott remains until November
- 2010 nov 95% completion of Roche Health Center outpatient clinic
- 2011 apr 1 Roche Health Center Clinic opens 2x/week

- 2011 autumn Graduate Elective Architecture Studio to address Medical Housing
- 2011-12 fundraising for Phase 2 of Roche Health Center
- 2015 projected completion of Phase 3: Complete Roche Health Center Facility

goals

1. DESIGN FOR ALL by providing a Health Center that addresses the needs of all members of the community
2. DESIGN FOR EDUCATION by incorporating teaching and learning into every area of the health center
3. DESIGN FOR REPRODUCIBILITY by creating buildings using locally available materials and construction techniques
4. DESIGN FOR SUSTAINABILITY by minimizing energy usage, natural resources and material usage
5. DESIGN FOR PERMANENCE by producing safe, durable, repairable buildings
6. DESIGN FOR THE FUTURE by incorporating flexibility and adaptability



roche health center master plan

fall 2010

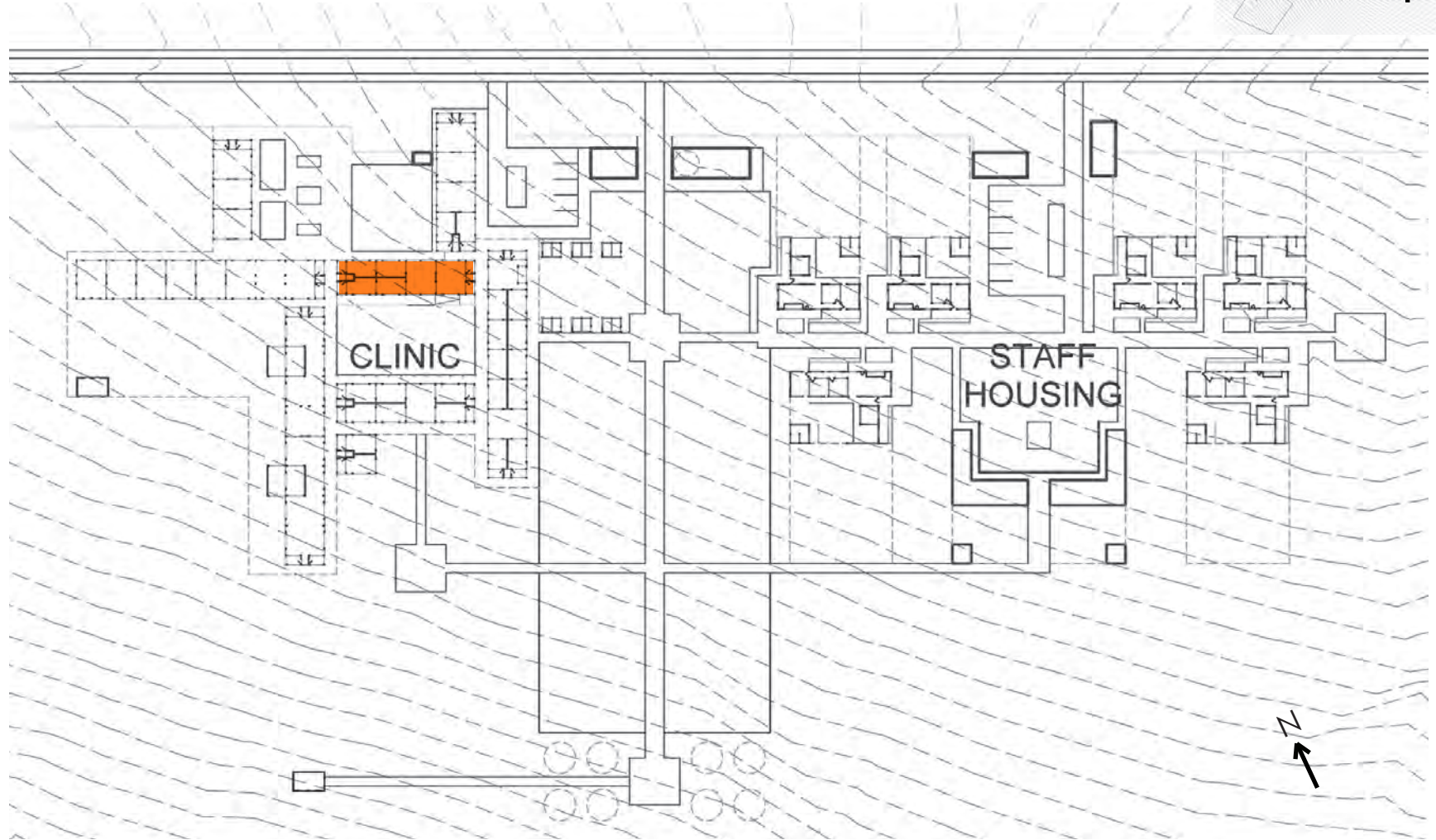
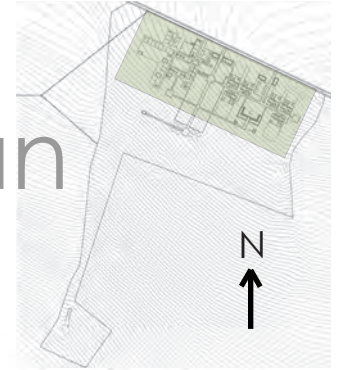

VLOP

www.villagelifeoutreach.org



Founded in 2004, Village Life Outreach Project, Inc. is an official 501 (c)3 non-profit organization based out of Cincinnati, Ohio whose mission is to **unite communities to promote Life, Health and Education.**

Most of Village Life's work focuses on three remote and impoverished villages in the Rorya district of Tanzania, East Africa: Roche, Burere and Nyambogo, all located near Lake Victoria.

VILLAGE LIFE GUIDING PRINCIPLES

- Partnership
- Sustainability
- Collaboration
- Long Term Commitment to Communities

“Village leaders identify their own needs,” Dr. Chris Lewis, VLOP Founder, explains. “Then we strategize with them on how to solve those problems together. This buy-in solidifies the idea that they are going to do their part. It’s a ‘hand up rather than a hand out’.”



HEALTH: VLOP Founder, Dr. Chris Lewis, examining a child at a mobile field clinic



EDUCATION: Roche students enjoying Uji porridge provided by VLOP's Nutrition Project



LIFE: Village Water Committee members learning how to build water filters

SHED

www.shedfoundation.org

The Shirati Health, Education and Development Foundation

SHED is a Tanzanian non-governmental organization (NGO) and VLOP's partner on-the-ground. SHED helps coordinate VLOP's various projects in the Rorya District, and assists with managing the construction of the Roche Health Center. Their work is focused in the areas of Health, Education and Development in underserved Tanzanian communities.

Through the partnership and support of local and international donors, SHED's objective is to:

- provide relief assistance to needy communities;
- provide support for HIV/AIDS orphans;
- provide cancer research and treatment referrals;
- provide malaria prevention awareness; and
- promote clean water and environmental issues.



VLOP Brigade June 2008 with SHED



Oct 2008 UC Students meeting with SHED



Oct 2008 VLOP meeting with SHED

UC-SAID

<http://www.daap.uc.edu/said/>

University of Cincinnati (UC) School of Architecture and Interior Design (SAID) in the College of Design, Architecture, Art and Planning (DAAP)

The School of Architecture and Interior Design at the University of Cincinnati prepares students for **critical engagement with practice**. This critical engagement presupposes sustained evaluation of principles, traditions, and requirements of building in all its aspects, interior and exterior.

Our goal is to **advance the professions of architecture and interior design by combining ethical judgment and technical proficiency in pursuit of excellence**, whether the product of our expertise is a physical or intellectual construction.



In view of constantly changing conditions for practice, our program seeks to multiply insights and abilities in every student:

- sensitivity to the aesthetic and social responsibilities of environmental intervention
- the life-long cultivation of a broad, synthesizing, and humanistic world view
- respect for the benefits of research and innovation
- deepened commitment to specific lines of inquiry
- an advanced understanding of the culture of practice
- readiness for professional responsibilities
- design acumen, advanced graphic skills and technical vocabulary
- affection for risk and love of play

The Master of Architecture (MArch) program was listed in 2009 as the #6 Accredited MArch program in the US based on *Design Intelligence* ratings.



COLLEGE OF DESIGN, ARCHITECTURE, ART, AND PLANNING



ARUP and the ARUP CAUSE

http://www.arup.com/About_us/Making_a_difference/Communities_and_causes.aspx

In fall 2008, ARUP began a collaboration with the Roche Health Center design team. In 2008, we worked with ARUP Chicago and in 2009, we worked with ARUP Los Angeles and ARUP San Francisco.



On November 14th, 2008, our studio traveled to Chicago to meet at ARUP's office. We presented to the team and introduced our project and process to the ARUP team.

We addressed Structure, Water Supply, Sanitation, Mechanical, and our overall master plan.

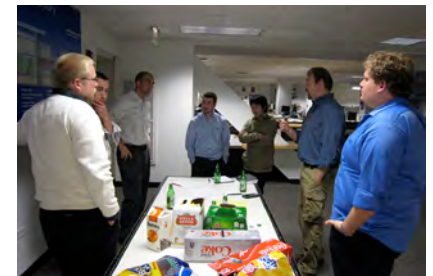

emersion DESIGN

<http://www.emersiondesign.com>

From emersion's website:

Emersion DESIGN is a Cincinnati-based collaborative practice driven by a passion for exceptional designs that advance clients & society.

Strong relationships with our clients are the core of what we do.

We understand that the built & the natural environment are inextricably & vitally linked. We commit to our responsibility as stewards, through our work & through our membership & leadership in the US Green Building Council.



why

NUMBER OF INHABITANTS PER DOCTOR



why

benefit a community in need

This is **Elvis Osira**, a 24-year-old farmer in Roche. When his wife went into labor with their first child, they had to walk 6 hours on rough roads to reach a hospital where they could receive the medical attention required to ensure the health of the mother and child.

The Roche Health Center is being built for Elvis and all of the other villagers of Roche, so that they can have access to the basic health care that all people deserve.



why

benefit and educate our own communities



why

benefit and educate our own communities



roche health center site

a new center for roche village

The Roche Village Health Center site is approximately 21 acres on a gently sloping site.

Latitude: 1° 19' south

Longitude: 33° 58' east

Altitude: 1132 meters



assumption

It's Africa, it must be hot

Latitude: 1.5 S

Longitude: 33.5 E

Elevation: 3753 feet (1143m)

Heating Degree Days: 0

Cooling Degree Days: 1182

Temperature: typically 60 - 90° F

Relative Humidity: maximum RH % is 74.2

Comfort Zone: 73° F - 83° F

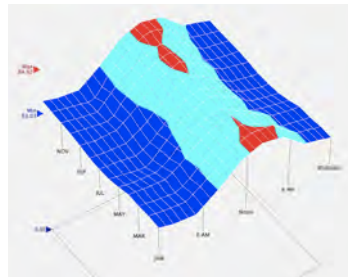
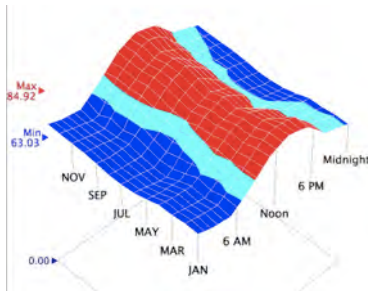

discovery

- it's not as hot as expected
- relative humidity is very low
- thermal comfort is culturally specific

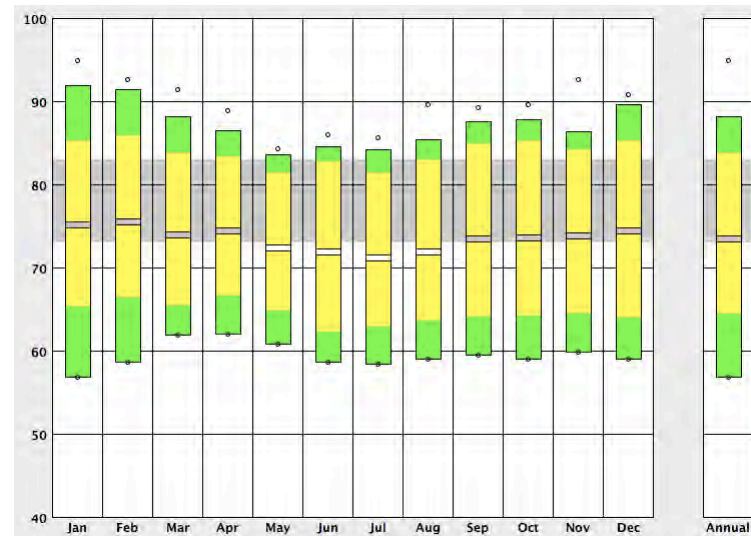

I've never seen anyone uncomfortably warm inside, even when we are sweating.

Chris Lewis speaking about experience of temperature in these villages

WEATHER DATA SUMMARY		LOCATION: KISUMU, -, KEN												
		Latitude/Longitude: 0.1° South, 34.75° East, Time Zone from Greenwich 3												
		Data Source: TMY3-637080 637080 WMO Station Number, Elevation 3759 ft												
MONTHLY MEANS		JAN	FEB	MAR	APR	MAY	JUN	JUL	AUG	SEP	OCT	NOV	DEC	
Dry Bulb Temperature (Avg Monthly)		75	75	73	74	72	71	71	71	73	73	73	74	degrees F
Dew Point Temperature (Avg Monthly)		59	60	62	64	64	61	60	60	59	61	61	61	degrees F
Relative Humidity (Avg Monthly)		60	62	70	72	77	73	70	68	64	68	68	67	percent

bio-climatic chart

passive strategies

This graphic analysis shows the monthly temperature data for this region on a psychrometric chart. Then, the data is analyzed to assess which passive strategies would be most successful for this climate based on time spent in that location on the chart annually.

Comfort Zone 73 - 83 F

28% of the year, the weather is within the typical human comfort zone.

COOLING

35% of the year, **shading** would be beneficial to reduce heat gain.

16% of the year, **thermal mass** would be beneficial to reduce heat gain.

18% of the year, **natural ventilation** would be beneficial to reduce heat.

HEATING

47% of the year, **internal heat gain** can be utilized for heating.

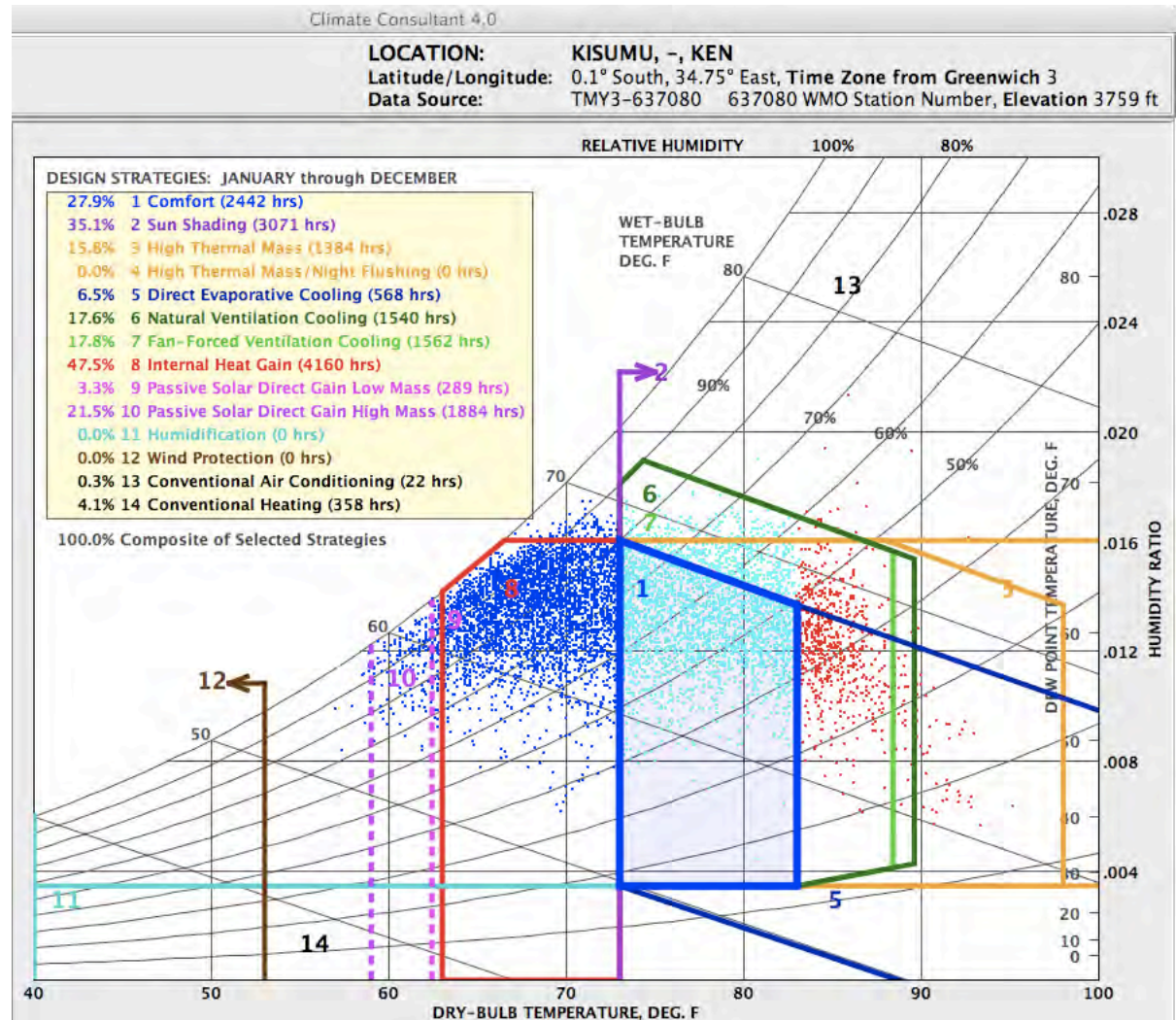

passive strategies

shading

The first priority to keep the interior spaces cool is to shade the outer walls. However, because of the low east and west azimuth angles in the morning and afternoon, respectively, shading complete won't always be reasonable.

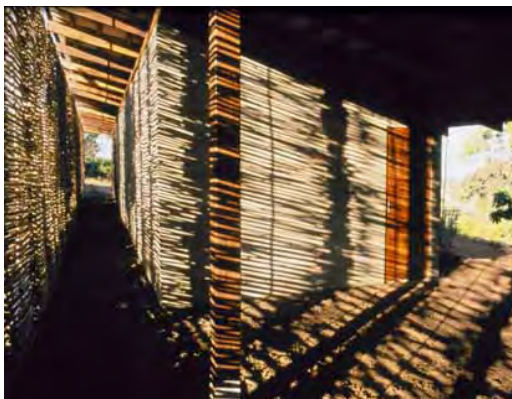

thermal mass

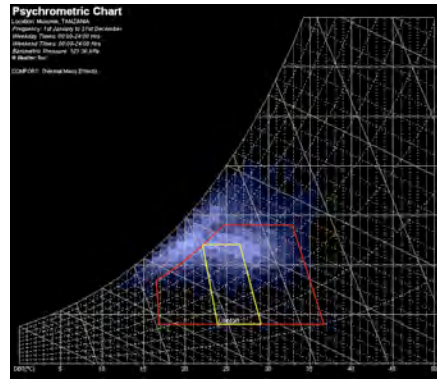

Using a substantial thickness in the walls will create thermal lag through each day. Thermal mass in the wall, floors, or ceilings will absorb the sun's energy during the day, mitigating interior heat gain. At night the wall will release the heat energy, keeping the interior space moderate even during cool nights.



natural ventilation

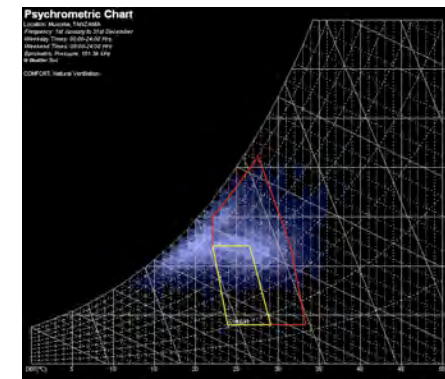

The most comfortable spaces are those with a breeze. Orienting the building according to wind patterns will increase the thermal comfort inside.

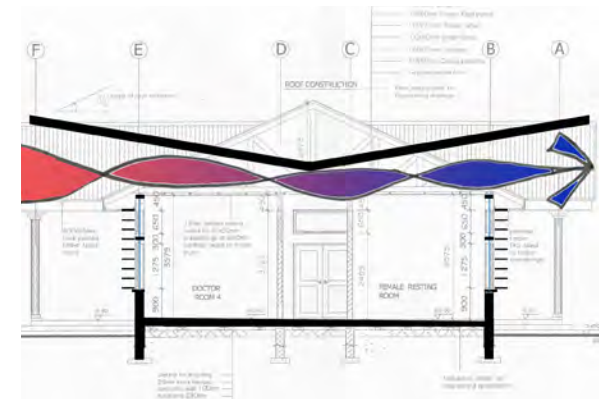

environment

solar availability / exposure

daylight availability and shading

Given the location on the equator, there is a nearly constant 12 hours of daylight per day throughout the year. Additionally, the East and West sun will be both important and challenging to shade because of the low morning and evening azimuth angles.

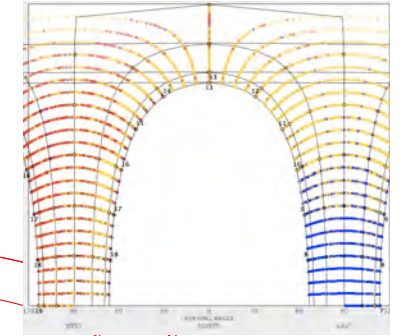
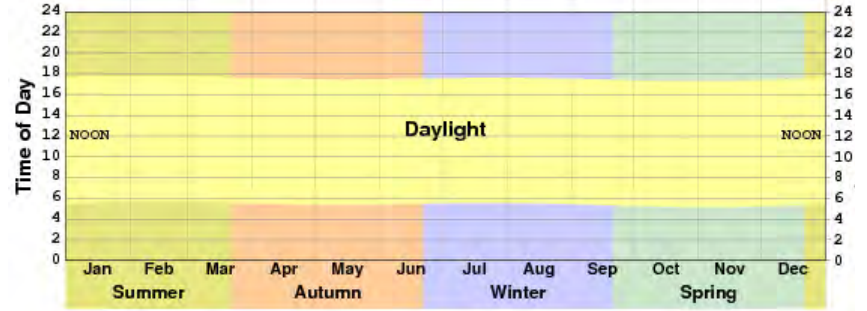

(c) Univ. of Oregon SRML
 Sponsor: EWEB
 Lat: -1.4; Long: 43
 (Solar) time zone: 3
 Shirati
 Tanzania

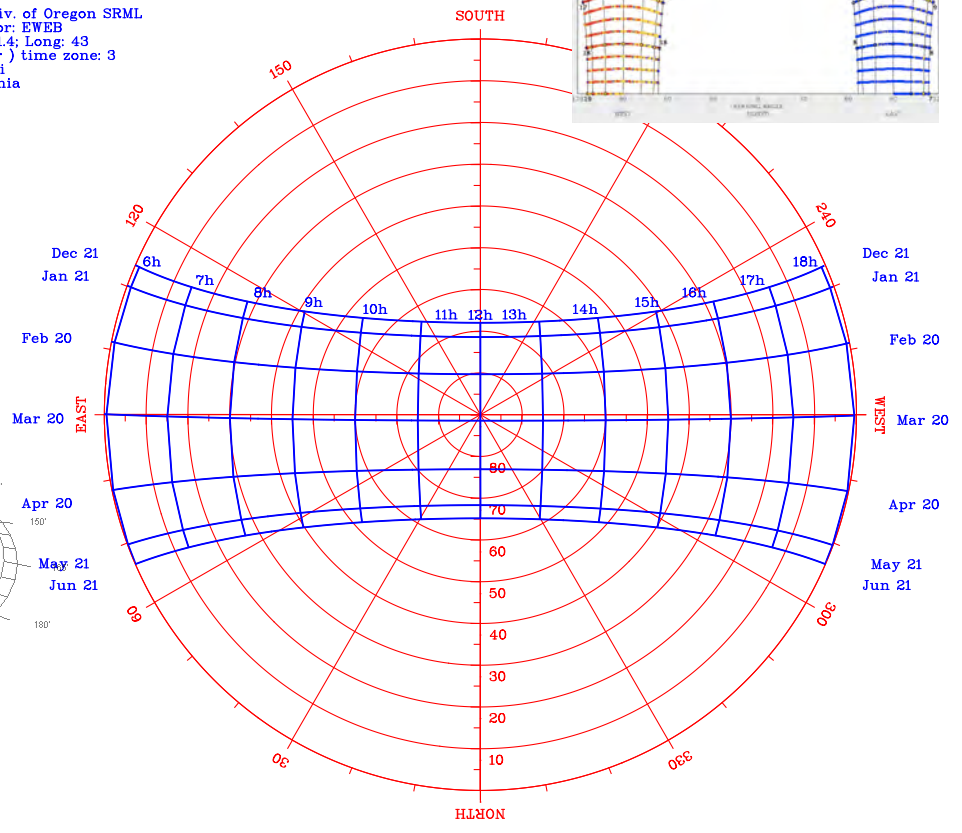
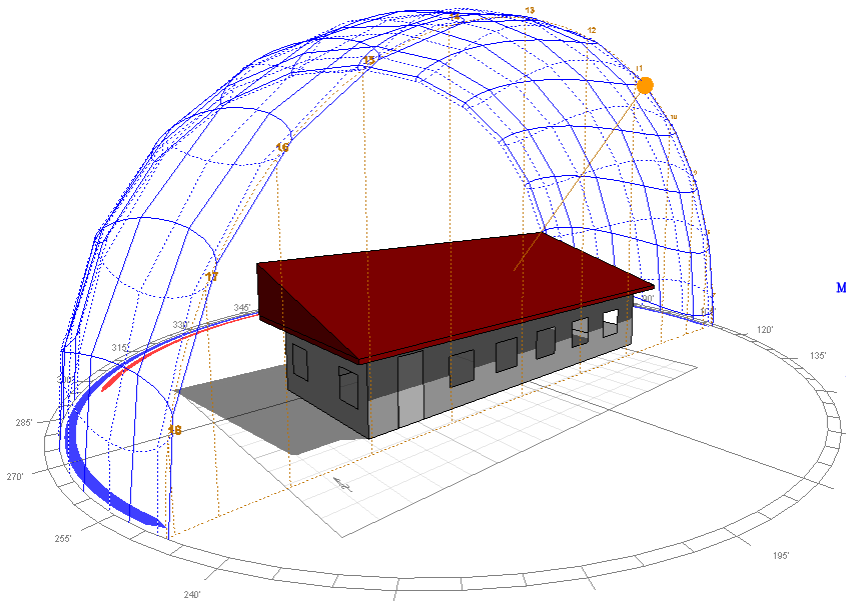

environment

sun / shading

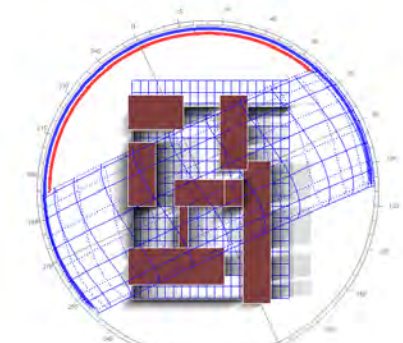

Shadow Range - Annual

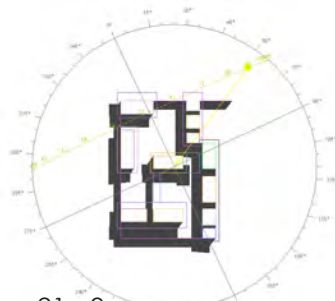

June 21 - 9am

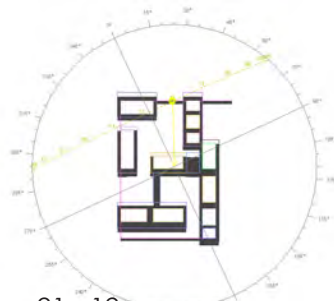

June 21 - 12pm

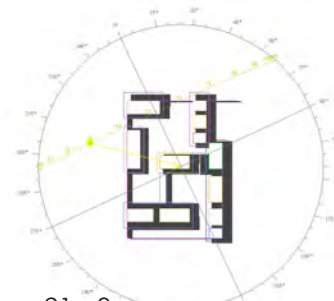

June 21 - 3pm

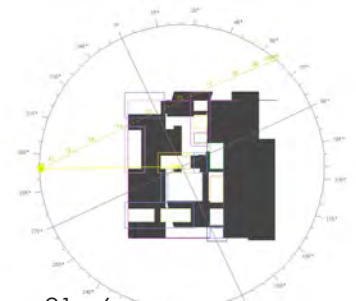

June 21 - 6pm

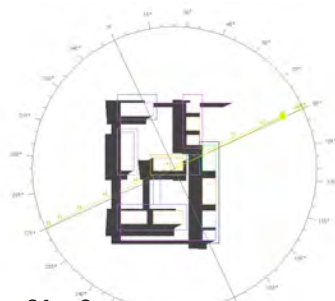

Mar 21 - 9am

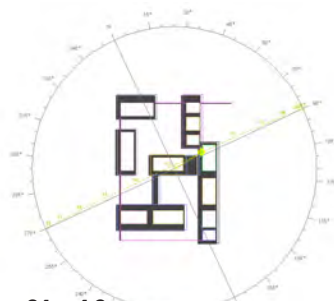

Mar 21 - 12pm

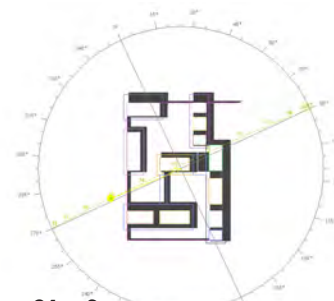

Mar 21 - 3pm

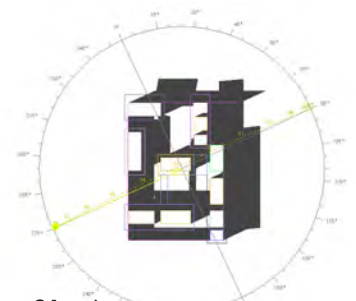

Mar 21 - 6pm

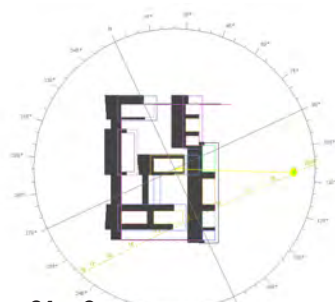

Dec 21 - 9am

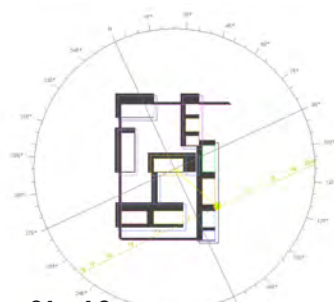

Dec 21 - 12pm

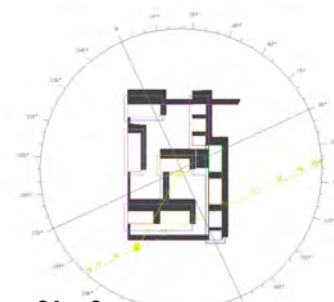

Dec 21 - 3pm



Dec 21 - 6pm

orientation for minimizing heat gain

minimizing solar exposure

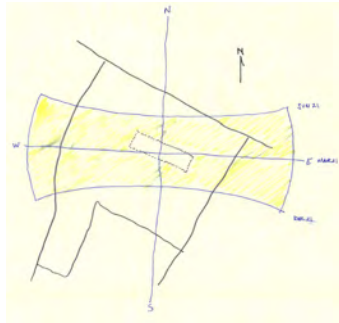

maximizing ventilation

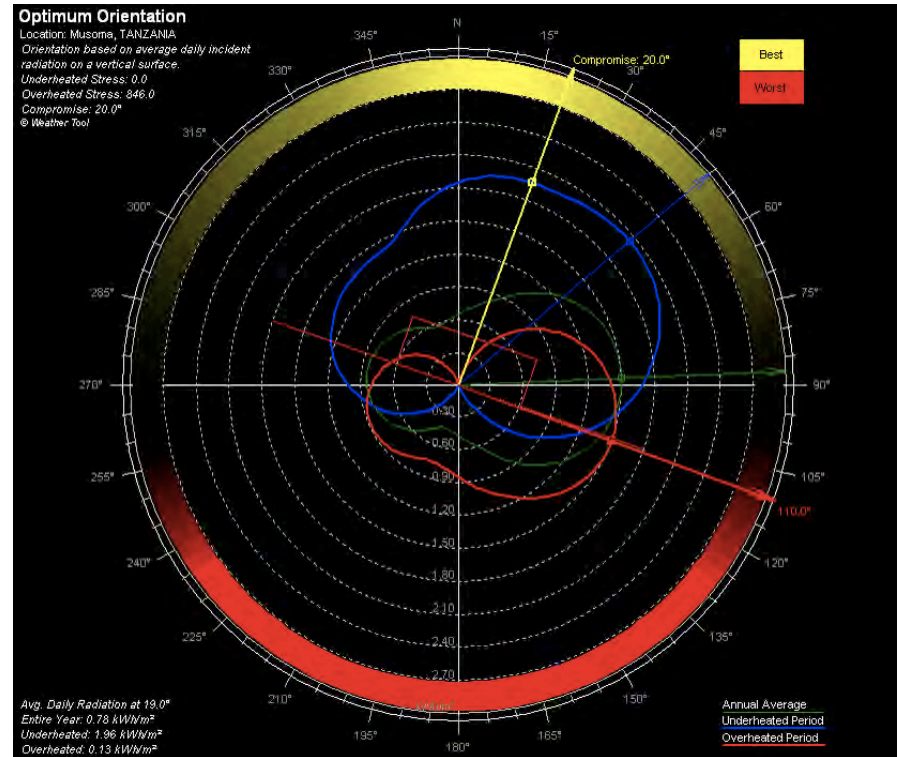
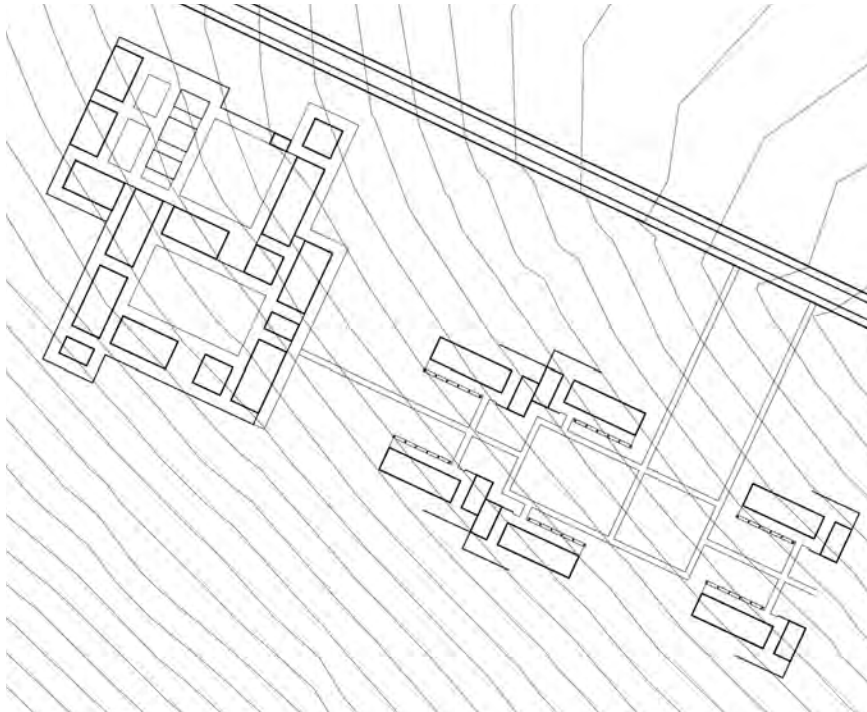
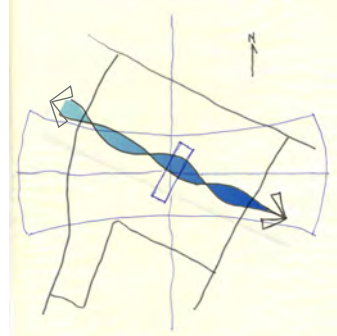

assumption

there will be power available

reality

A. through design, we can eliminate the majority of our power draws

B. any power that is needed, we must provide at the site

Demand: housing and clinic

- housing: 2.2 kW if all kitchen apps use fuel
- clinic: 4.2 - 4.8 kW
- lighting: efficiency vs availability

Supply: renewable energy options

- solar insolation available
- wind speed and direction
- power during rainy season
- maintenance
- cost
- on-site fuel-based generators as back-up

renewable energy sources

solar thermal, solar electric and wind

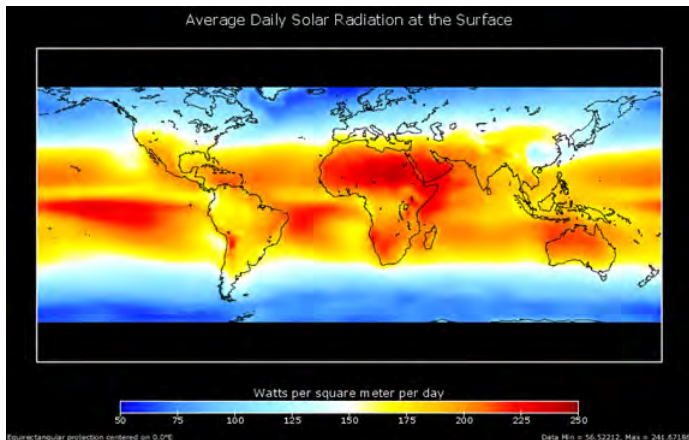

Benefits:

- unlimited source
- clean
- safe

Challenges

- expensive
- not viable during rainy seasons
- batteries
- maintenance
- theft



Benefits:

- unlimited source
- clean
- safe

Challenges

- not enough wind
- expensive
- theft
- batteries
- maintenance

renewable energy sources

people power

Playpump



Sadly, somewhere along the way, PlayPumps stopped being a smart homegrown idea and became a donor-pleasing, top-down solution that simply didn't fit many of the target communities.

from article 'Some NGOs CAN adjust to Failure: The Play-Pumps Story' by Laura Freschi at www.aidwatchers.com

Benefits:

- clean
- safe

Challenges

- cost \$14,000 (4x more than base pump)
- requires a lot of hours to be effective
- uses calories that may be needed elsewhere

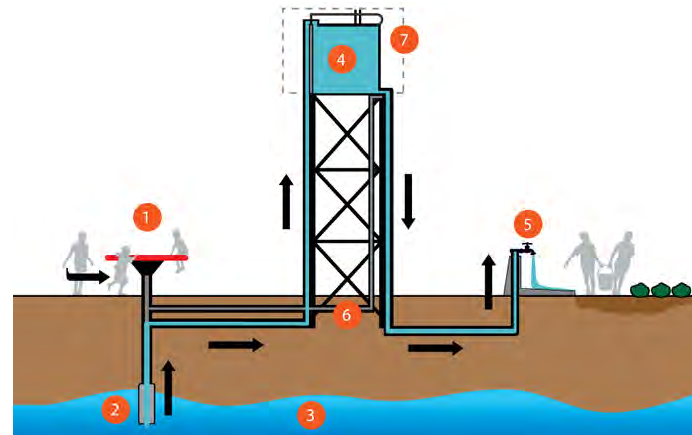

electric lighting

efficiency, safety, longevity, durability

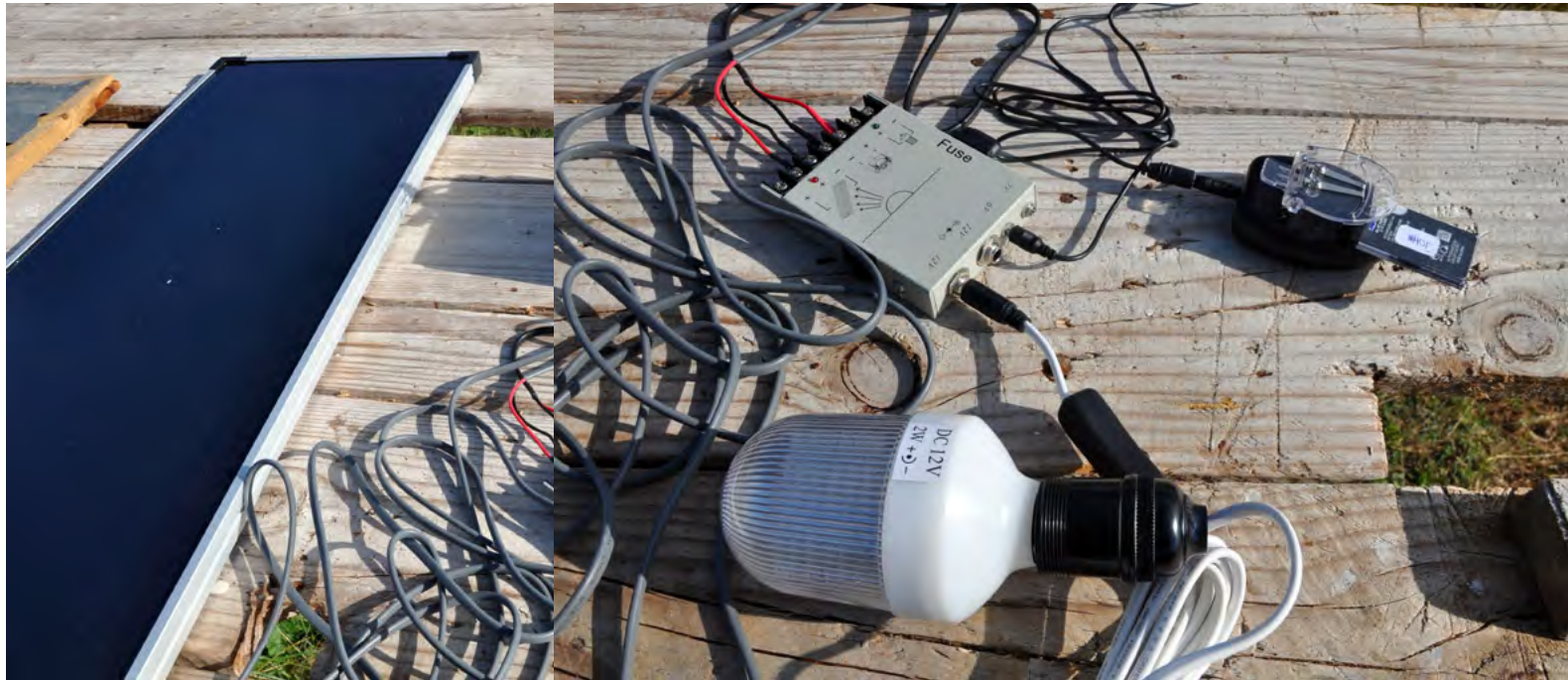

- Purchased in June 2011
- (1) 12-watt panel (temporary)
- (1) 36-watt panel (to be premanently installed)
- (6) 2-watt lights
- (2) solar cell phone battery chargers

assumption

There will be clean water available when I turn on the tap

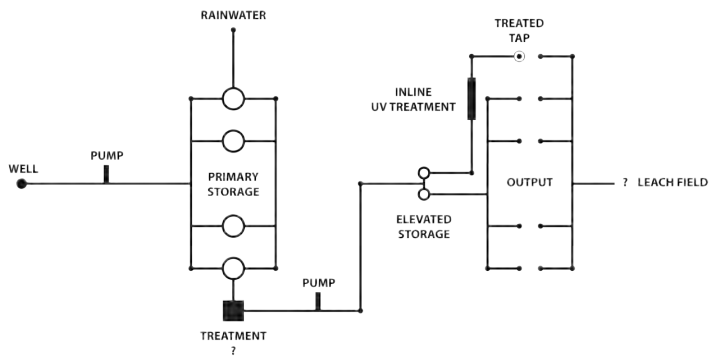

reality

There is no infrastructure for water collection, storage, distribution, filtration or disinfection

- **Demand:** housing and clinic
- housing: 80 liters/day/person
- clinic: 600 liters/day based on similar clinics
- **Supply:** rainwater collection and pump (?)
- pump is a huge unknown
- **Water system:**
 - collection (roofs and pump)
 - long-term storage (potential filtration)
 - pump to elevated storage (dual tank)
 - filtration and disinfection
 - water heating
 - delivery (potable + secondary)
 - waste water

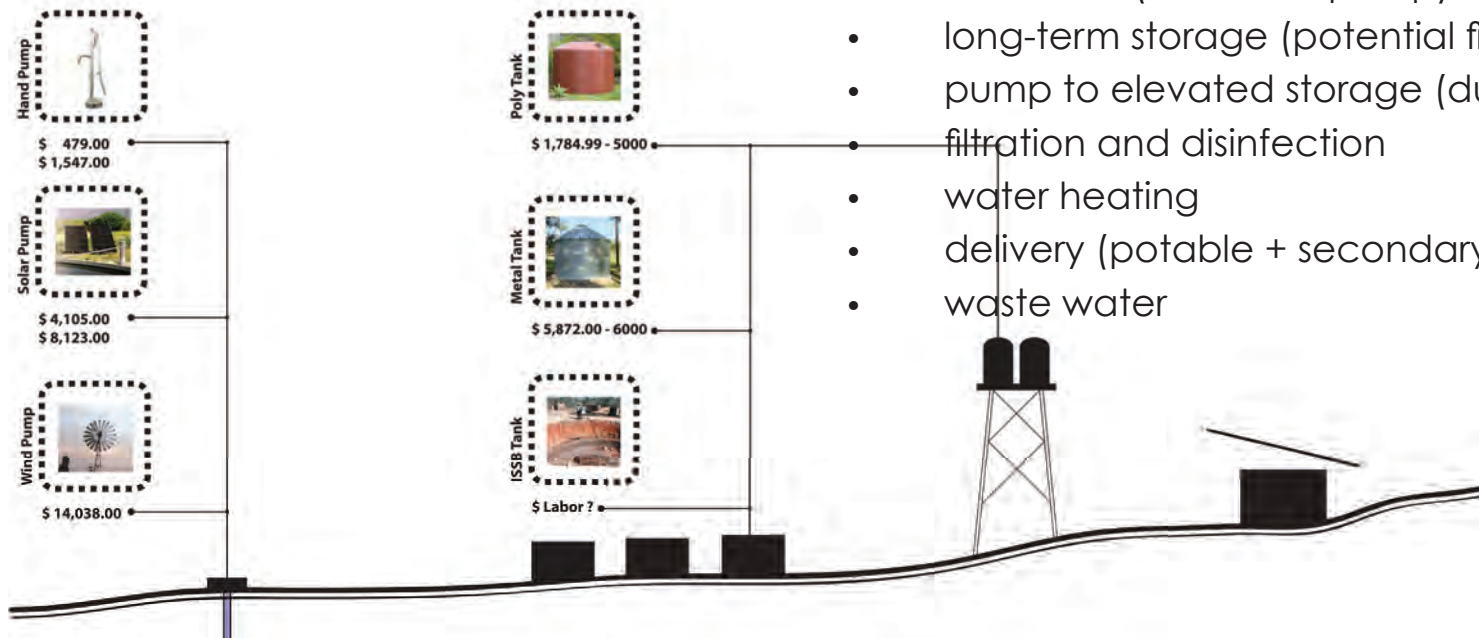

assumption

it's not worth saving water in this dry region

discovery

a 1,000 sf roof with a 3,000 gallon storage tank can collect enough water for a 5-person family for over half of the year

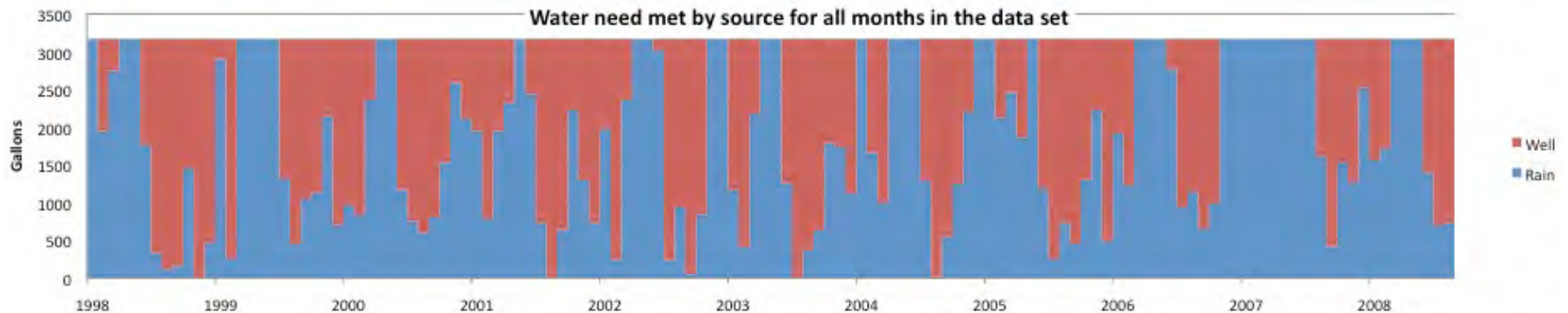
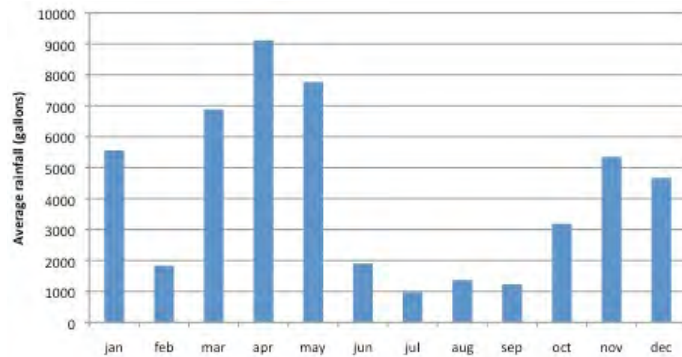

assumption

the health center will be purely for healthcare

discovery

the clinic will be for much more than healthcare

community hub

educational resource for

health, sanitation and construction

commerce

precedent for other health care centers in TZ

site design

two regions: community & housing

The community region consists of two main courtyards which organize the public buildings and the clinic buildings. The doctor's and nurse's housing complex sits to the southeast.

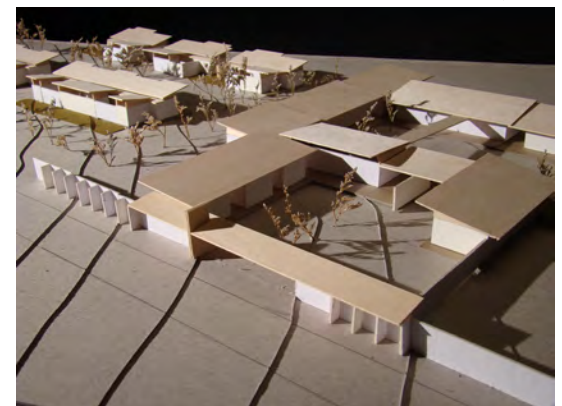
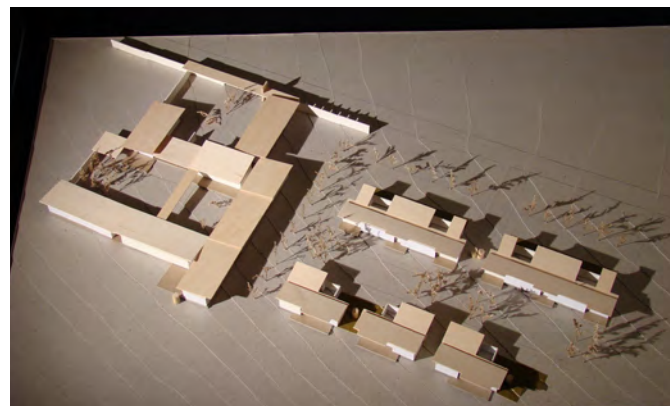
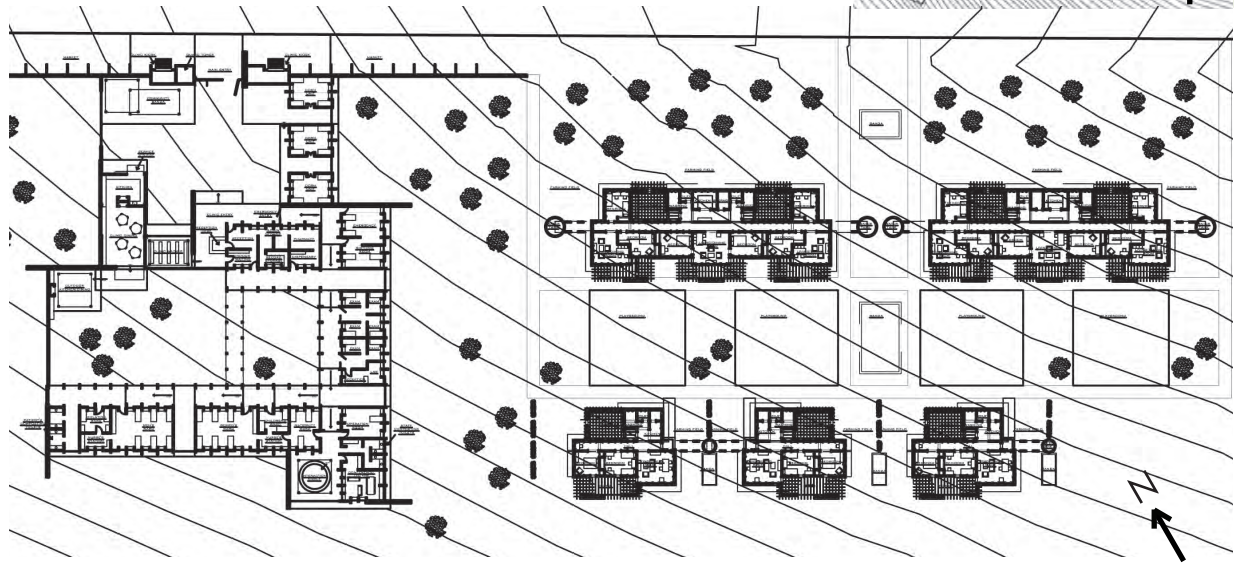
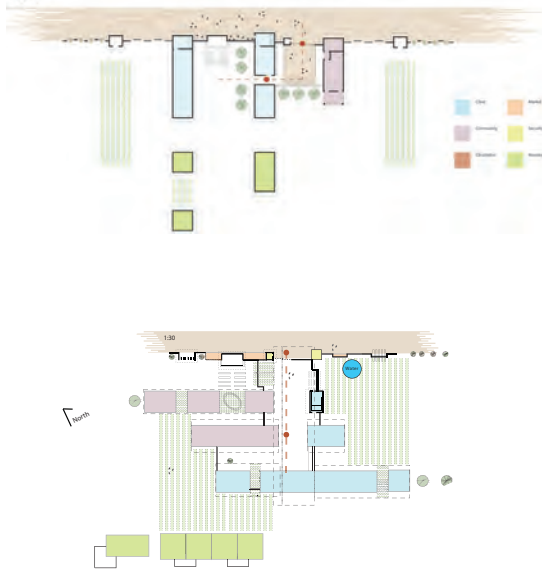
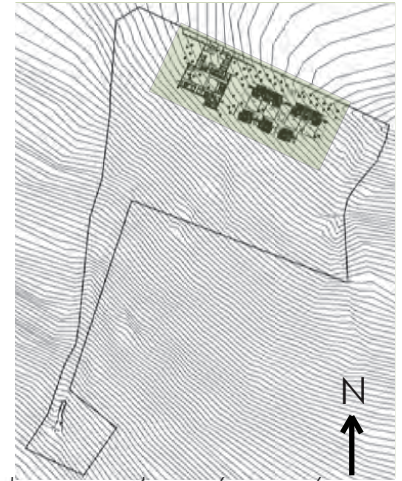

a center for health and more

The health center complex has three layers of privacy:

- public along street
- semi-public courtyard
- clinic courtyard

Market space lines the street front with a guarded entrance into the first courtyard, which contains a large, outdoor multi-purpose space, dorms for the patients' families, and an education space.

The clinic is divided into three parts: administration, out-patient, and in-patient.

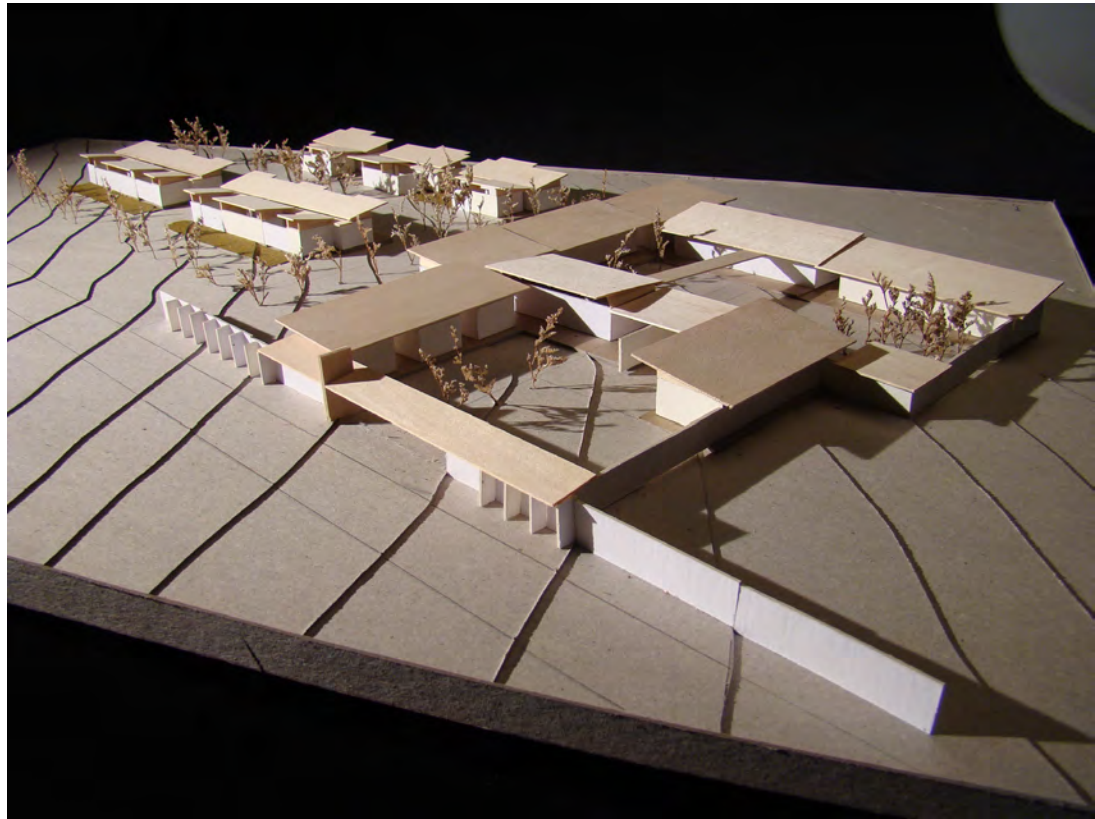
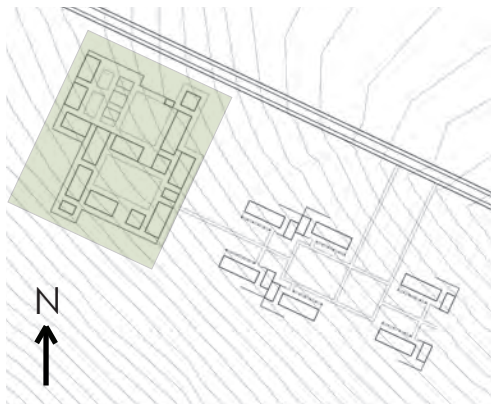

master plan

two regions: healthcare & housing

The master plan is a modular system with a set of simple buildings bounding a series of outdoor spaces with infrastructure integrated throughout the site.

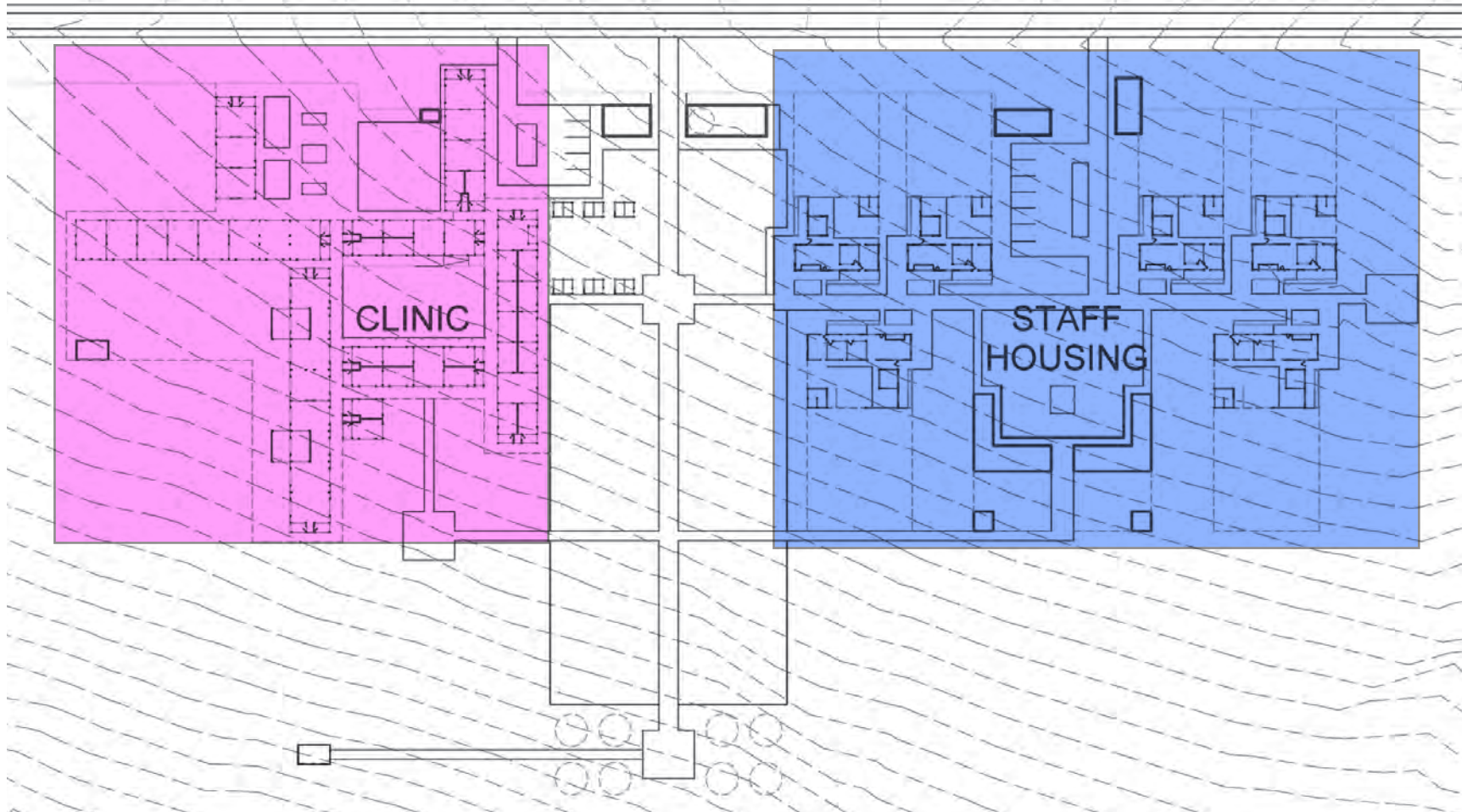
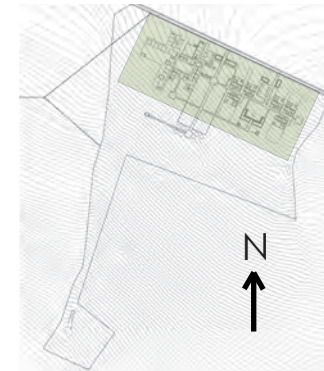

assumption

vernacular construction is a great resource for ideas



discovery

there are cultural stigma attached to specific materials and construction



contemporary construction

post-1961



assumption

the existing method for wall construction should be retained because it is common



discovery

there is a much better option for producing soil blocks



material exploration

ISSB



Earthen Floors



Rammed Earth



The graduate architecture students from the Fall 2008 studio at the University of Cincinnati built mock-ups of earthen blocks, earthen floors and rammed earth. One important discovery was that the calories required for rammed earth was unrealistic without machine tools (which are not available in this region).

precedent

similar climate/material: stabilized earth blocks

Heikkinen-Komonen Architects
Helsinki, Finland

School for Chicken Farmers
Kindia, Guinea, 1998

Poultry farming is an important area of development in food production, because chickens consume little plant protein, but yield many times the amount as animal protein.

In recent years, the development aid organisation Indigo, in collaboration with the Finnish Poultry Farmers' Association, has supported the development of chicken farming in Guinea.

This year a small educational unit will be built onto the Kaheré chicken farm, consisting of a school building, student dormitory and teacher's home. Each course contains 12 students.

The main technical objective is to minimize brick making, transportation and the use of imported materials.

The main building material for both the walls and the floor will be stabilised earth blocks. The roof will be made from 3 mm thick fibre-reinforced tiles. These materials will be made on the site in hand-operated presses.

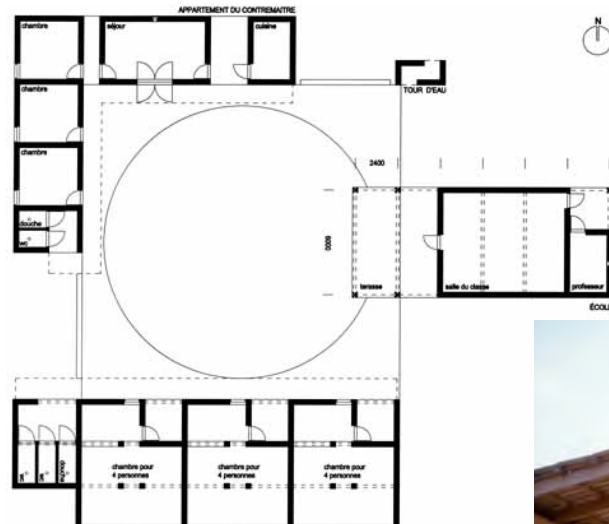

existing wall construction within the region



proposed wall construction within the region



assumption

**Whatever materials we design
with can be found**

discovery

**there is an limited palette of materials
available locally**

- **no power tools**
- **wood**
- **rough sawn lumber**
- **up to 2x6**
- **about 12' max length**
- **very little structural steel**
- **concrete is not structurally sound**
- **few long fasteners**
- **no safe glass**
- **corrugated sheet metal**
- **few plastic materials**
- **no sheet goods other than thin press board**

available materials

Tarime Hardware Store



reproducibility

One of the strongest driving forces in this project has been the desire for the project to be reproducible, instructing local villagers in stable construction techniques throughout the process that they can apply to their own homes. This stems from Village Life Outreach's tenet "a hand up, not a hand out". Because of limited technology and materials available in the region, this goal is at times in conflict with another goal, that

of longevity. Within this project, a balance must be found between producing a building that the villagers can emulate, and a building that will remain durable over time. The graphic at the right shows the distances to the towns in which construction materials are located. The graphics below, from left to right, are examples of the details on the following pages, and illustrate through color-coding their degrees of reproducibility.

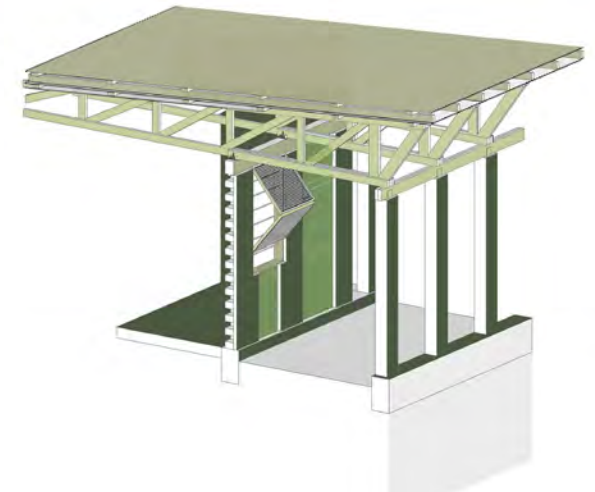
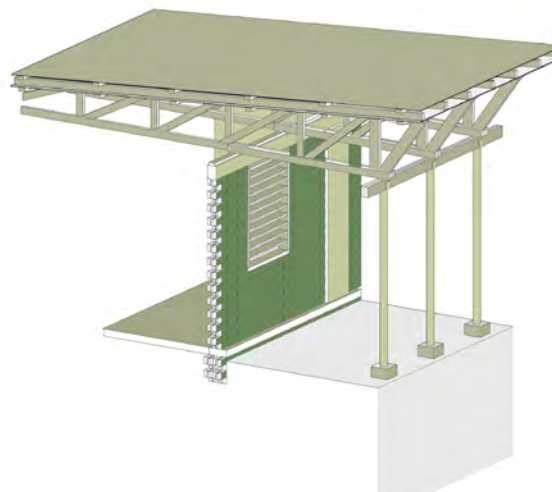
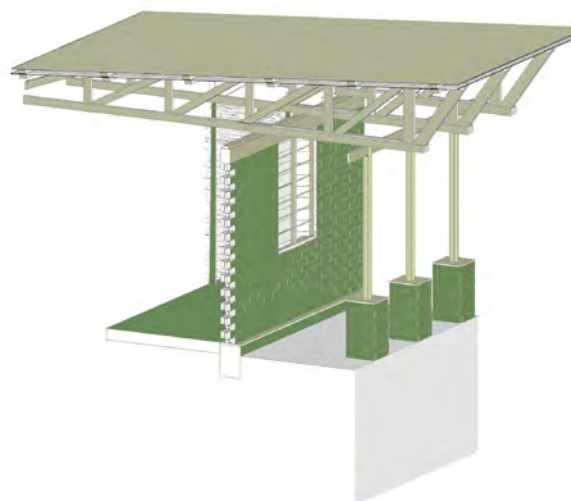
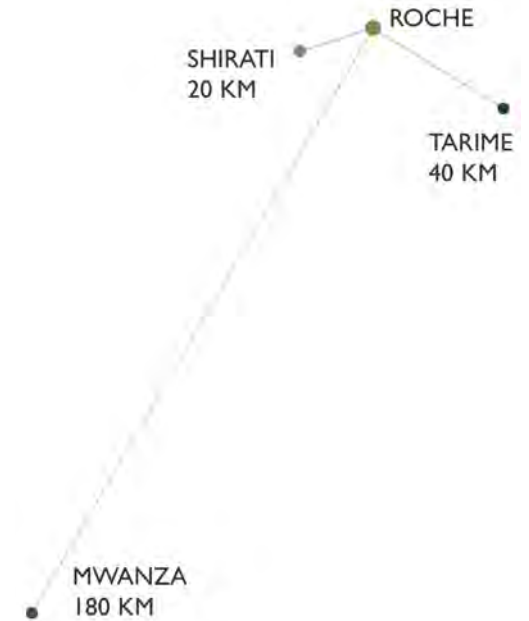

TARIME MWANZA SHIRATI ROCHE

typical roof design section

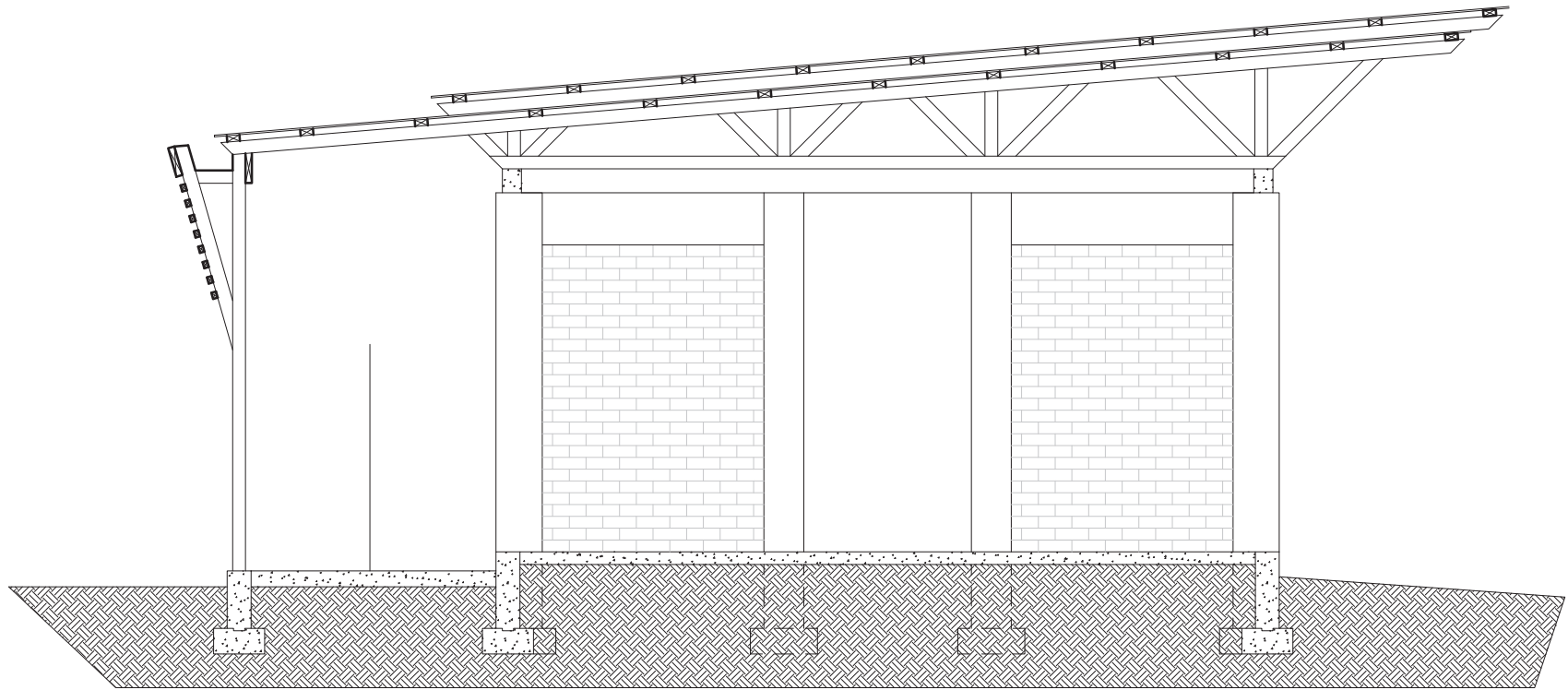

11

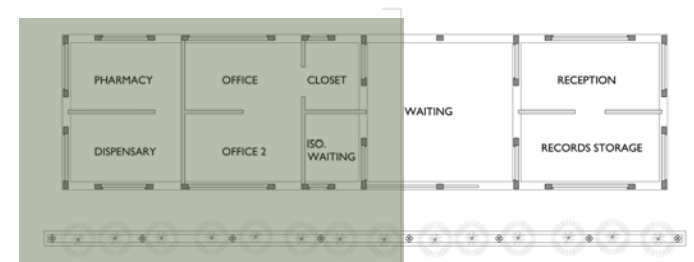

materials

roof materials

galvanized metal roof



The typical roof in the region is galvanized metal sheets over wood trusses. They are not typically repainted or re-finished, so they rust eventually, leaving spaces unprotected from the sun. In addition, the internal radiant heat gain is extreme during the overheated season.

We have found a higher quality metal roofing locally which has paint chemically bonded to the surface on both sides to resist rust. In addition, the light color will significantly reduce the heat transfer to the interior.

We intend to use a double roof that will likely have two layers of metal to reduce heat transfer as well as reduce noise transfer from rain.

acoustic testing

Acoustic testing was conducted on four roof conditions. An insulated box was placed tightly against the underside of each roof mock-up. Water was then sprayed at a constant pressure and a reading taken by a sound meter. In each successive condition sound readings decreased indicating that the perceived volume of the monsoon rains on the roof may decrease by more than one half, allowing conversations even during these periods of heavy rainfall.

Roof layers:

- 2x6 rafter
- 2x4 purlin
- corrugated metal sheet



acoustic testing

Version 1

Roof layers:
 2x6 rafter
 2x4 purlin
 corrugated metal



Results

Though 99db is extremely loud, this is merely a reference point and basis for comparison.

Version 2

Roof layers:
 2x6 rafter
 1 corrugated metal
 1x3 furring
 1 corrugated metal



Results

Given that decibels are measured logarithmically, a decrease of 10db is equivalent to a 50% decrease in noise. Therefore, a decrease of 6db is significant.

Version 3

Roof layers:
 2x6 rafter
 2x4 purlin
 1 corrugated metal
 1x3 furring (on end)
 1 corrugated metal



Results

By positioning the furring on end, the gap between the layers of metal was increased from one inch to almost three inches. This resulted in significant sound deadening.

Version 4

Roof layers:
 2x6 rafter
 2x4 purlin
 1 corrugated metal
 1x3 furring (on end)
 1 corrugated metal
 press board "insulation"



Results

In this experiment a press board similar to those available near Roche was added as both a ceiling and an insulator. This addition resulted in a further decrease of 4dB, and overall improvement from the first version of 14dB.

design development a modular system of local materials

design for daylight, ventilation, flexibility and replicability

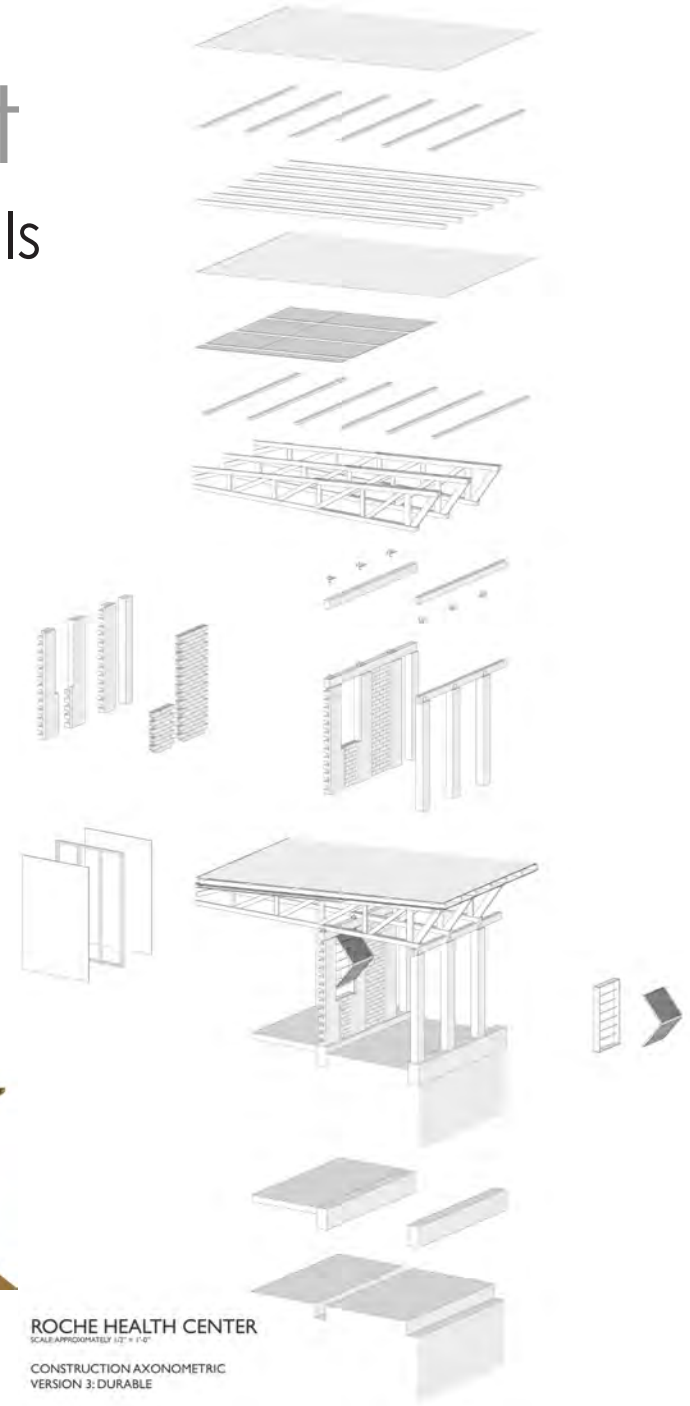
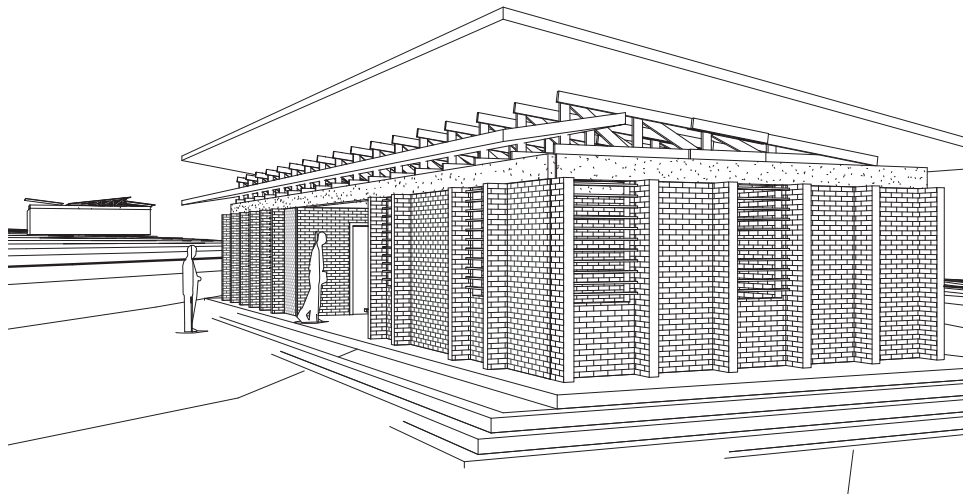

ROCHE HEALTH CENTER
SCALE: APPROXIMATELY 1/2" = 1'-0"
CONSTRUCTION AXONOMETRIC
VERSION 3: DURABLE

design development

confined masonry expression



phase one: outpatient clinic

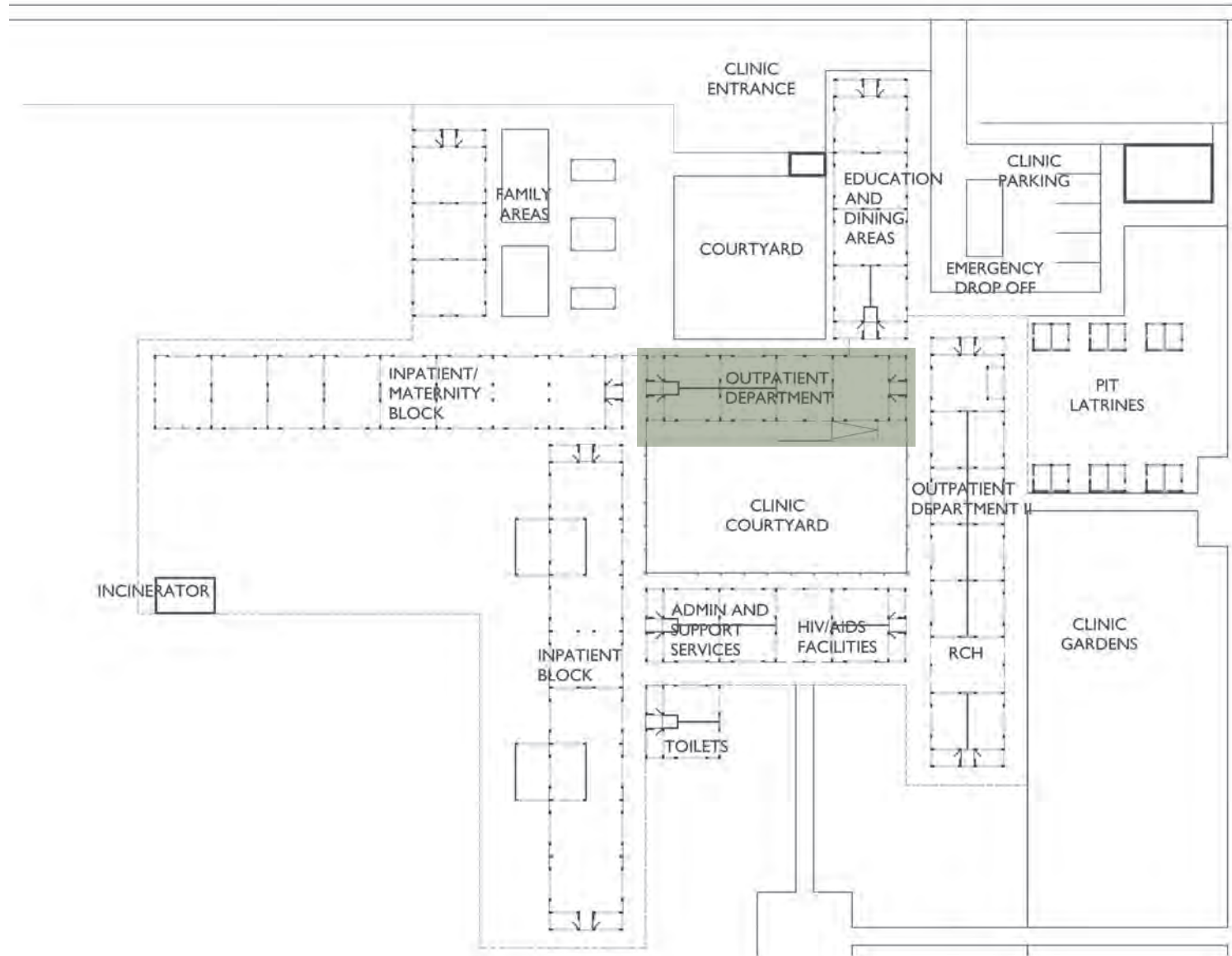

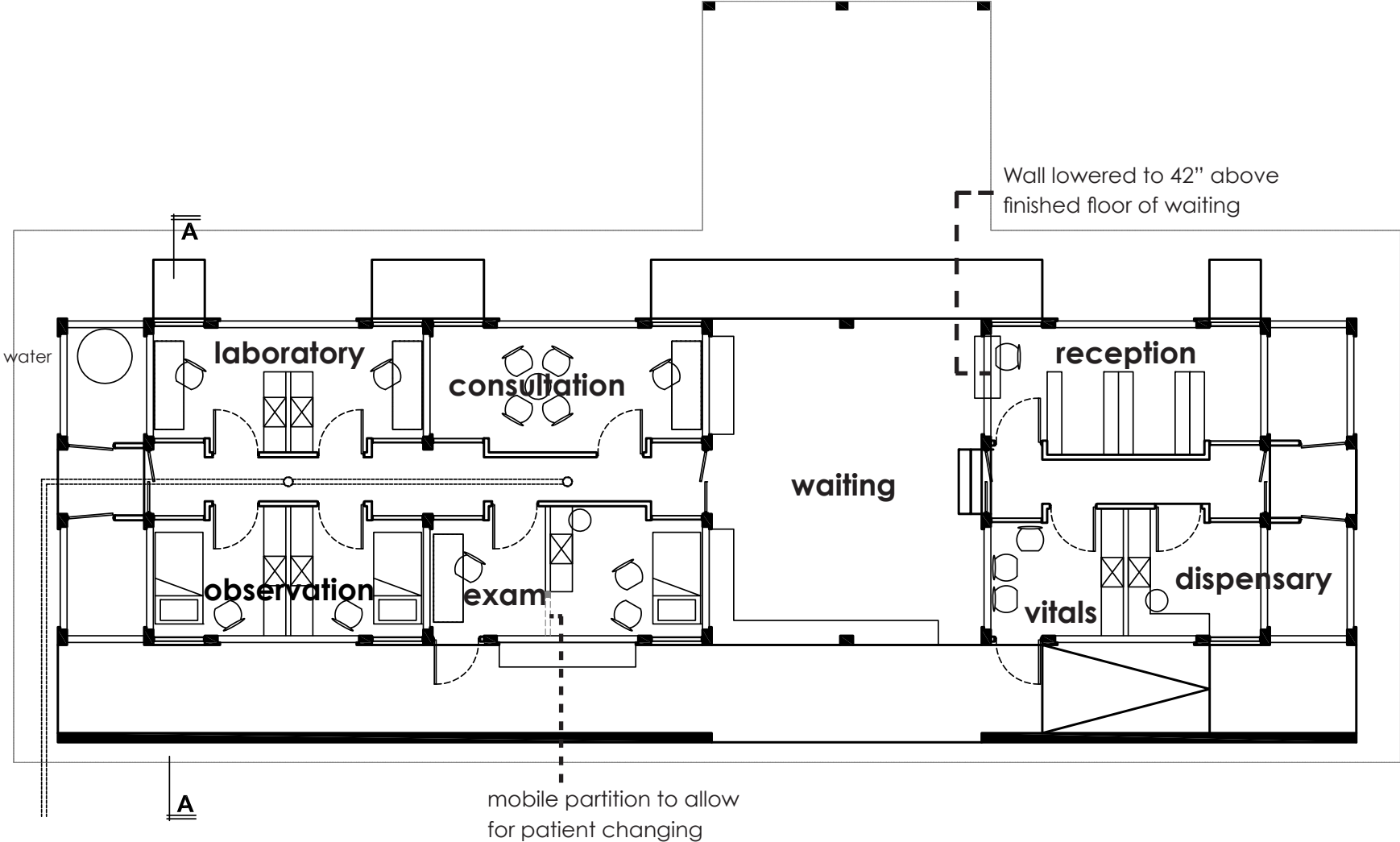

clinic floor plan

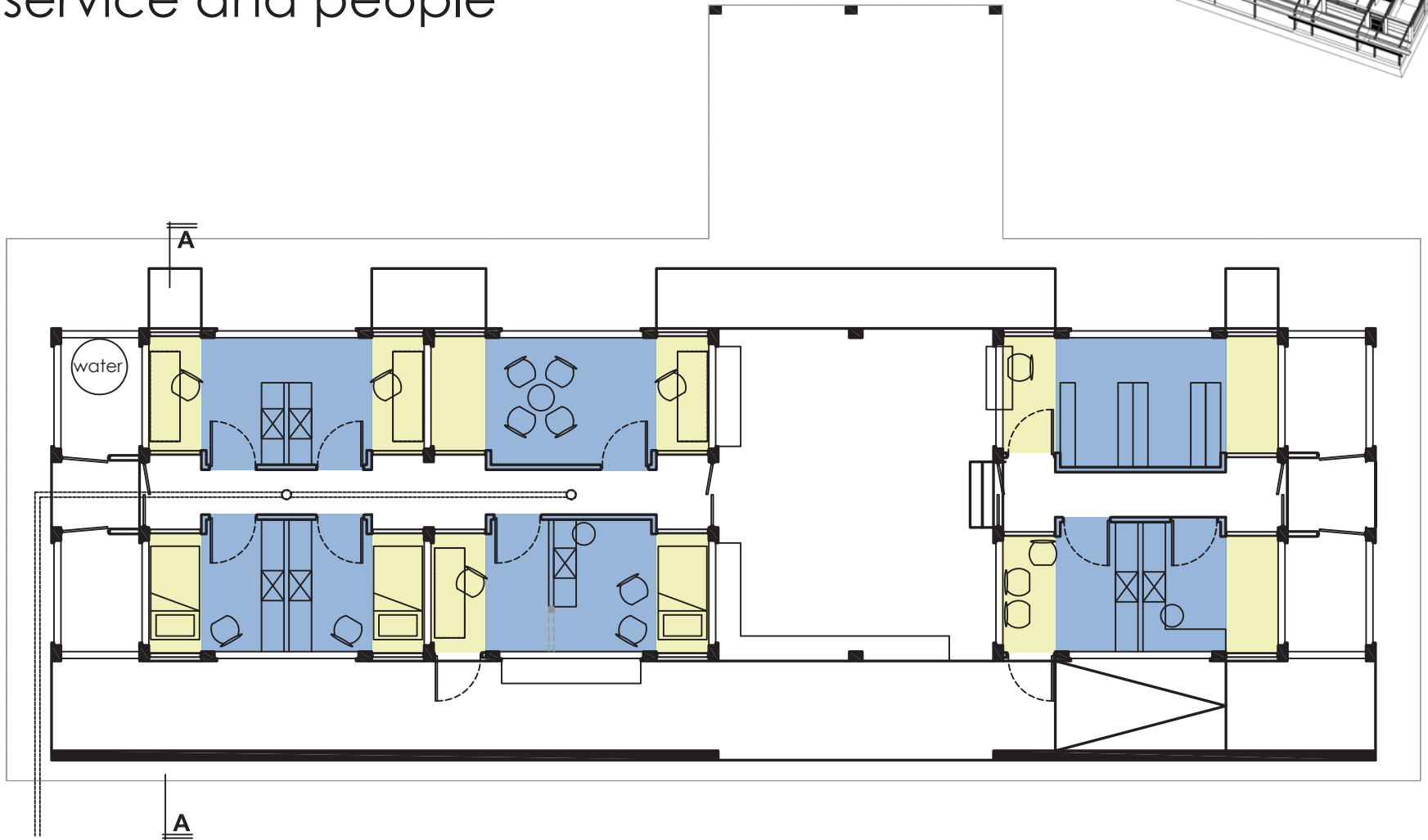
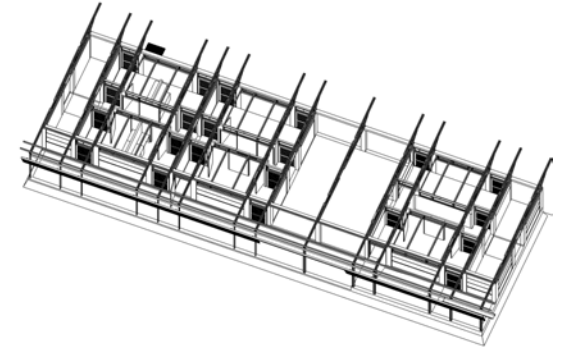

zones

service and people



-  service: storage, doctor tasks, water, circulation
-  people: patients, doctors, assistants, family

roche health center construction



construction

june 2010

Following on-site training from Makiga Industries (from Nairobi, Kenya), villagers produced over 7000 bricks for the construction of the outpatient clinic building of the health center.

On-site Project Director, Emily Roush and Professor Michael Zaretsky working with contractor, Julius and Roche Health Center workers.



local businesses on-site spurring economic development

Just days after construction began in May, 2001, small businesses began popping up near the site to provide food and shelter for the workers. They have organized a credit-based system whereby workers aren't required to pay until they receive their wages.



A "hotel" where workers can rest when needed.



Roche Villagers cooking beans and ugali for workers.

construction foundation



Images of foundation under construction.



View through Roche Health Center entry looking towards valley. Digital rendering collage over construction photo.

construction

ISSB walls emerging



construction concrete columns



construction ring beam



construction

roof truss



construction

roof sheathing



construction roof



construction nearing completion



construction

opened april 1, 2011



Roche Health Center Clinic



assessments

by Spencer Leuker of Clinton School of Public Service

AUGUST 2011

Evaluation Description

During ten weeks, 80 household interviews, extensive research into health center records and numerous interviews with village leaders and health center staff, I have been able to gather the appropriate data and community opinion of the Roche Health Center and its services for the first four months of operation. Of the 80 families interviewed, 30 have a family member who has received medical treatment, consultation, or vaccination from Roche Health Center. It is quite obvious that Roche Health Center has a strong presence in Roche village and the surrounding communities.

Roche Health Center is not only IN our community; it IS part of our community!
- from Roche Villager



assessments

by Spencer Leuker of Clinton School of Public Service

AUGUST 2011

Evaluation Description

In a little more than four months of operation, Roche Health Center has been able to do some amazing things and has made a difference in the lives of many people in the surrounding region.

From 4/1/11 to 08/12/11, Roche Health Center (RHC) by the numbers:

- 274 – Patients seen by RHC's doctors, nurses, and nurse assistant
- 159 – Villagers of Roche who have received medical care from RHC
- 152 – Children vaccinated against Polio, Diphtheria, BCG, and/or Measles
- 94 – Villagers of communities near Roche
- 69 – Patients treated for malaria
- 41 – HIV and Syphilis tests administered
- 39 – Clinics held on Tuesdays and Fridays giving vaccines and educating mothers on how to raise a healthy child
- 24 – Women seen for antenatal tetanus vaccines

Roche Health Center has attracted those in need of medical attention from all over the district and even from Kenya!



assessments

by Spencer Leuker of Clinton School of Public Service

AUGUST 2011

Evaluation Description

Most of those surveyed who have been treated at Roche Health Center traveled less than an hour for their appointment. Before the building of Roche Health Center, these patients would generally have to travel much longer to get to the closest clinic or hospital. The mean travel time to RHC was approximately 16 minutes, whereas the mean travel time to another clinic or hospital was over two hours!

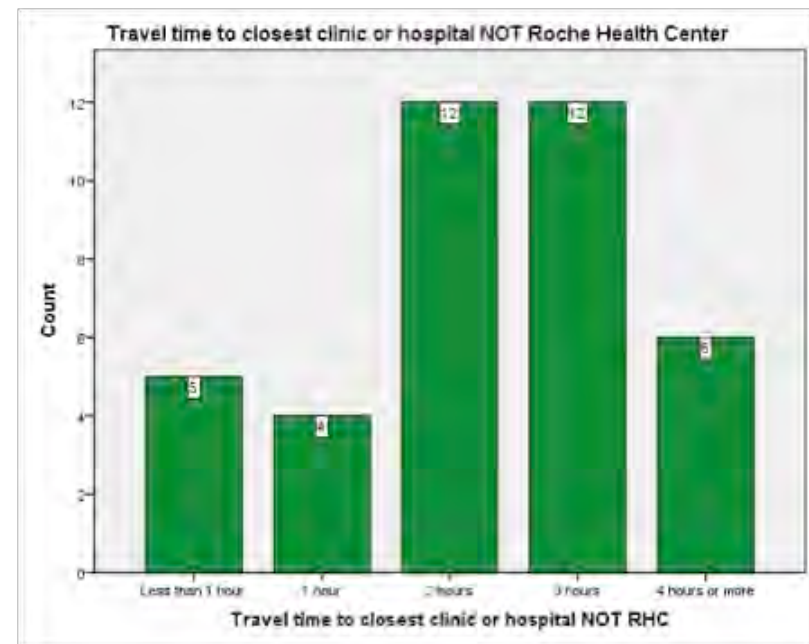
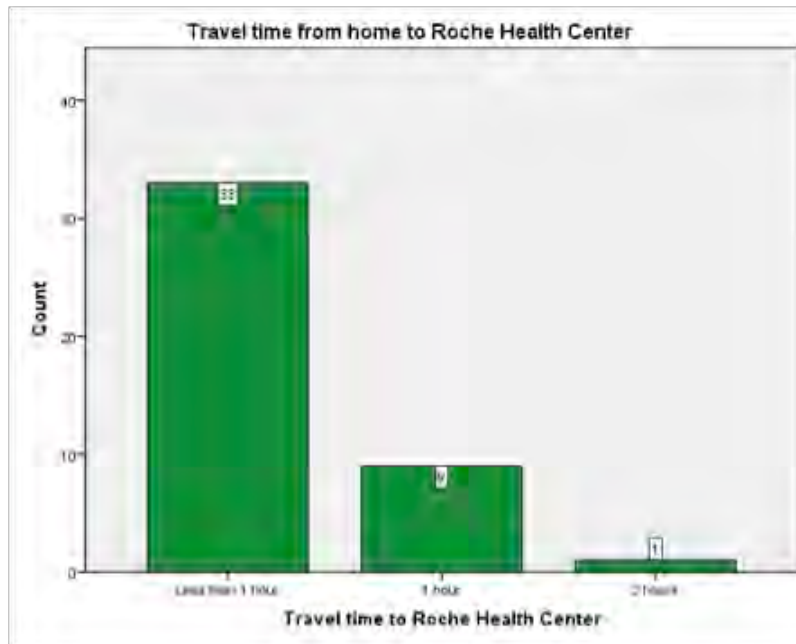

assessments

by Spencer Leuker of Clinton School of Public Service

AUGUST 2011

Evaluation Description

For the 30 families surveyed who have a member that have been treated at Roche Health Center, there are strong reasons to return for future treatment. For those 50 families that have not been to Roche Health Center, there are similar reasons to use Roche Health Center as the first choice in medical care.

Those interviewed cited proximity, good service, and a strong ownership of the health center as the main reasons to use Roche Health Center.

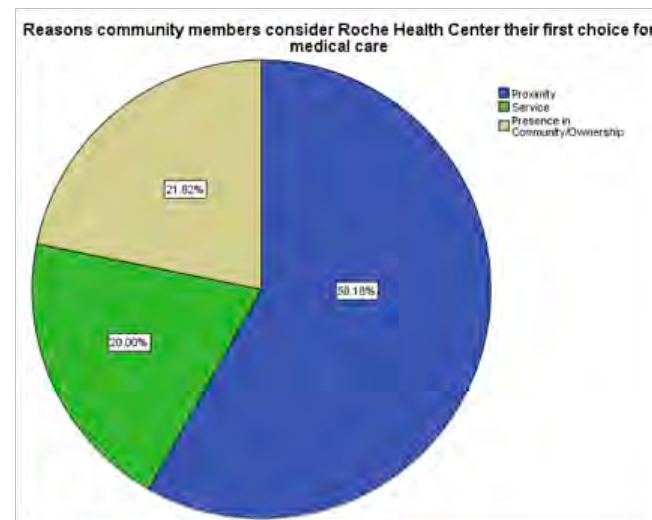
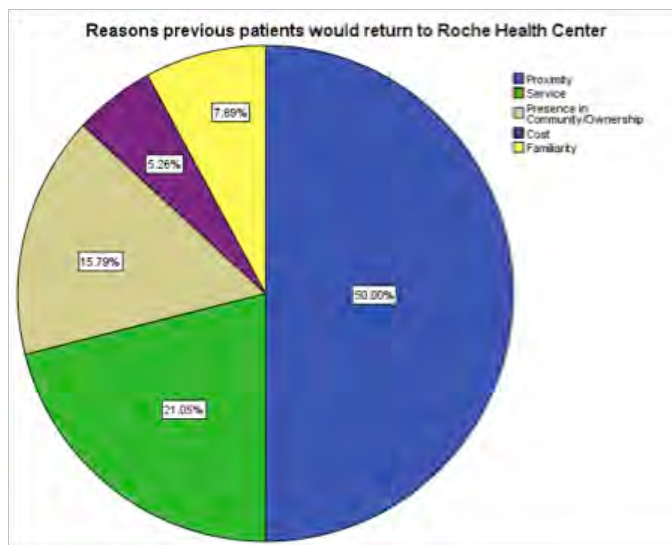

Kingigoro Primary School



